

**ULTRA·SHEAR™**  
WOODTURNING TOOLS  
by **Woodpeckers®**

# SIERRA - SIERRA NOMAD - SIERRA ELEGANT BEAUTY BALLPOINT PEN KIT

Instructions for Pen Kit Model Numbers  
220028, 220029, 220030, 220031, 220032, 220033, 20116,  
220117, 220118, 220119, 220120, 220121, 220032, 220033



Finial/Cap Assembly



Twist Mechanism



Ink Refill



Brass Tube



Spring



Nib



## SUPPLIES NEEDED:

- 27/64" Drill Bit (Part # ND-01260)
- 3/4" x 3/4" Pen Blank
- Sierra Pen Kit Bushings (Part # 220233 or 25002)
- Replacement Tubes (Part # 220187)
- Ultra·Shear Pen Mandrel (Part # USPMD)
- Ultra·Shear Pen Mill-Ci (Part # PMCIDLX)

Shop all your pen making supplies at [woodpeck.com](http://woodpeck.com)

All Pen Kits have different parts. The Pen Kit and the finished pen shown are for reference of the part names and may not fully resemble the Pen Kit you have purchased.

If you think you're missing anything, email us at [mailroom@woodpeck.com](mailto:mailroom@woodpeck.com).  
You can also call us at 800-752-0725 from 9:00 a.m. to 5:00 p.m. EST Monday - Friday.

## PREPARING THE PEN BLANK/BRASS TUBE ASSEMBLY

1. Only one blank is required for this pen kit. Cut the material blank 1/8" longer than the brass tube. Excess will be cleaned up in a later process.
2. Drill the blank with a 27/64" drill bit. Typical speed will be between 900 to 1,200 RPM. **FIG A.**
3. Scuff the brass tube to eliminate any debris and this will rough up the tube for better adhesion.
4. Apply epoxy or CA glue to the brass tube and twist as it is inserted to insure proper coverage. Make sure you have the brass tube fully inserted and not sticking out the other end of the material blank. **FIG B.**

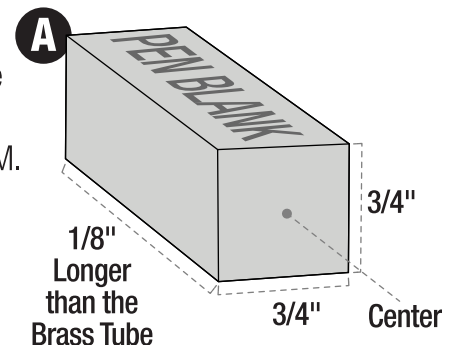

1/8"  
Longer  
than the  
Brass Tube

3/4"

3/4" Center

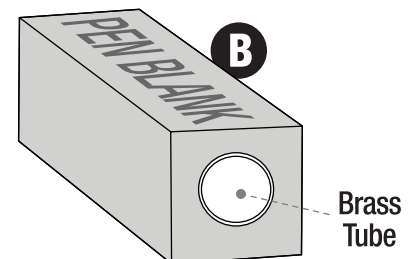

Brass  
Tube

5. Square the ends of the blanks to the brass tube. This process utilizes the Ultra-Shear Pen Mill-Ci. Place the material blank in a drill press vise and after selecting the proper reamer clean out the inside of the tub at the same time as you square the ends. **FIG C & D.**

### **!! COMMON ISSUES !!**

- **Proper material blank length. Your pens operation depends is dependent on having the proper length tubes.**
- **Not cleaning out all the glue from the tube causes pen failure.**

### **TURNING THE MATERIAL BLANK**

1. Assemble the blank on the Ultra-Shear Pen Mandrel using the proper bushings. In this case the set up is easy. Both bushings are the same. Tighten the bushings and material blank. No need to over tighten. **FIG E.**
2. Turn the blank to the desired contour, making sure the area next to the bushing is turning to the diameter of the bushing.
3. After turning the material blank, sand the surface in progressive steps. Depending on the material blank, wood, acrylic, hybrid you use a variety of sandpaper.
4. Apply the finish of your choice and polish.

### **ASSEMBLE THE PEN**

1. Press the Clip Assembly into the one end of you finished blank.
2. Insert the Refill into the Nib Assembly making sure the Spring is in place.
3. Screw the Twist Mechanism over the Refill and into the Nib Assembly.
4. Slide the blank over the Twist Mechanism and onto the Nib Assembly.
5. **Congratulations, your pen is complete.**

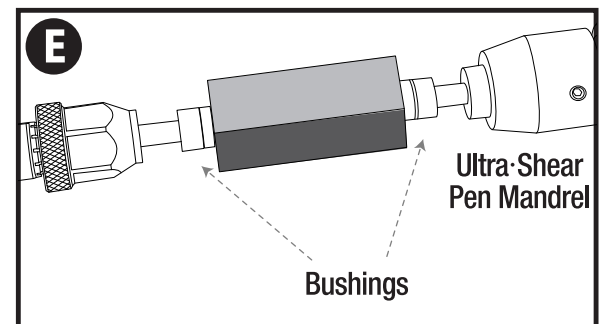
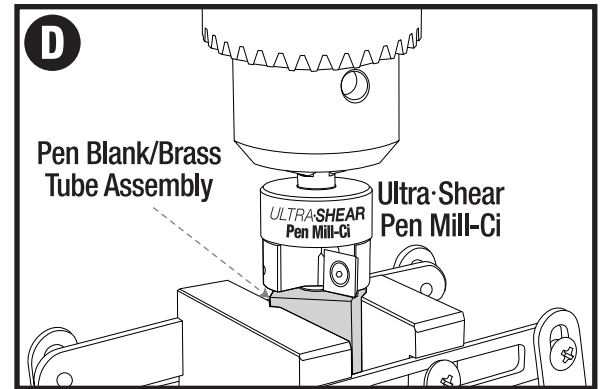
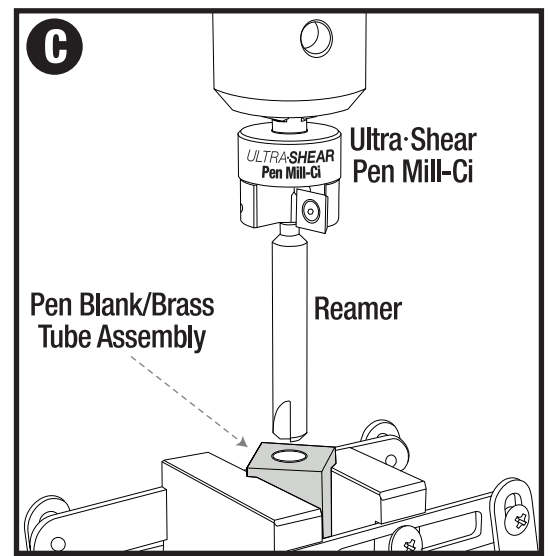

**ULTRA-SHEAR™**  
WOODTURNING TOOLS  
by **Woodpeckers®**

Woodpeckers, LLC Strongsville, Ohio · [woodpeck.com](http://woodpeck.com)

© 2020 Woodpeckers, LLC