

Woodpeckers®

CLAMP RACK-IT™ MOBILE

OWNER'S MANUAL

DIAGRAM NUMBER (QTY) PART NAME

- ① (1) Base
- ② (2) Rigid Casters
- ③ (2) Swivel Casters
- ④ (2) Legs
- ⑤ (2) Vertical Supports
- ⑥ (2) Horizontal Supports

HARDWARE BAG

- (16) 3/8"-16 x 1" Hex Bolts
- (16) 3/8"-16 Hex Nuts
- (16) 3/8" SAE Flat Washers
- (24) 1/4-20 x 1/2" Hex Bolts
- (28) 1/4-20 Kep Nuts
- (4) 1/4-20 x 3/4" Hex Bolts

CLAMP RACK-IT SYSTEM

- ⑦ (2) 24" Clamp Rack-It Backer Plates
- ⑧ (8) Clamp Rack-It Large Arm Sets
- ⑨ (6) Clamp Rack-It Small Arm Sets
- (56) 10-32 x 3/8" Thread-Forming Screws

HANDLE ASSEMBLY

- ⑩ (2) Handles
- (2) Grips
- (4) D-Washers
- (4) 5/8"-18 Jam Nuts

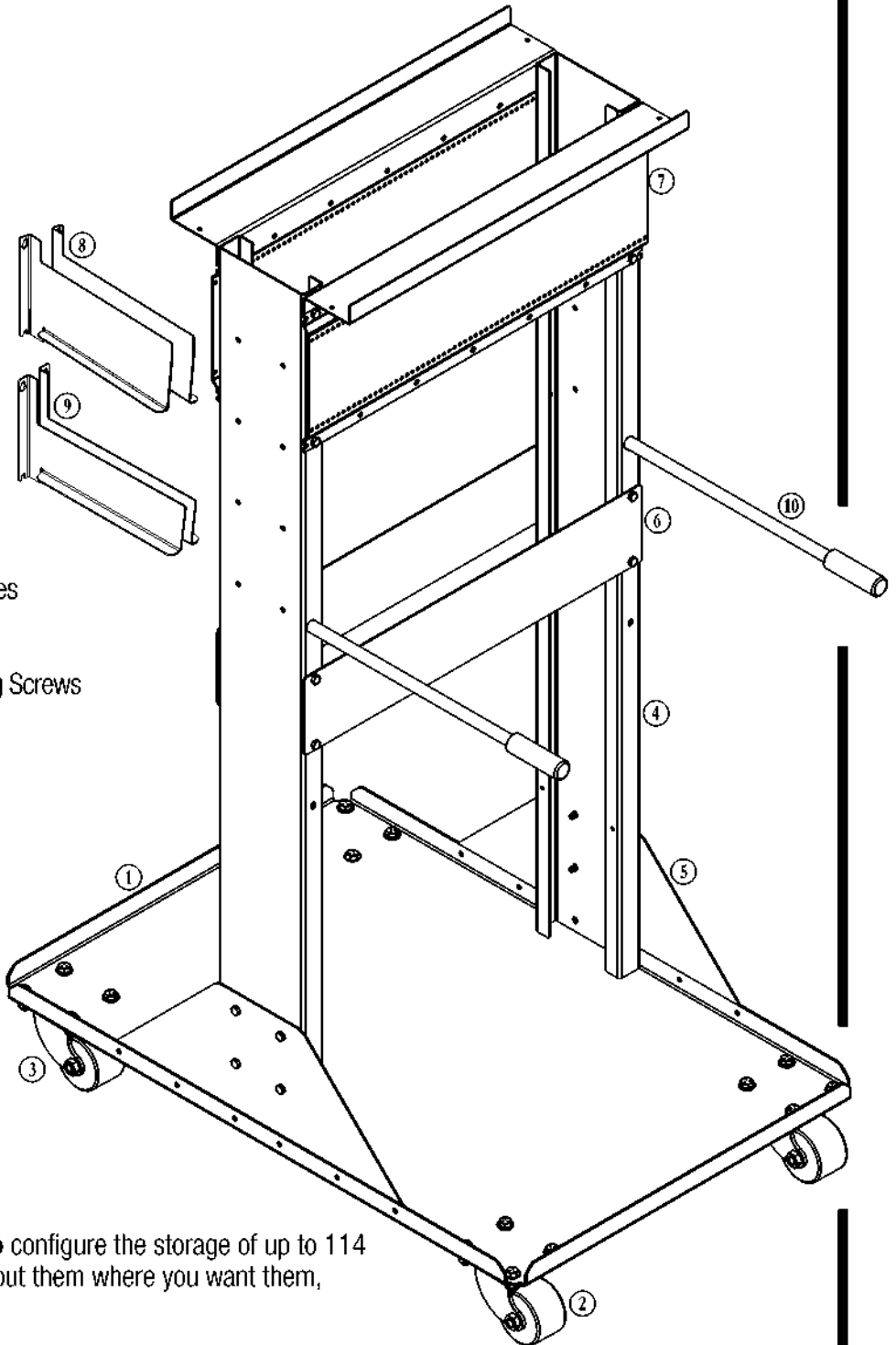

The **Clamp Rack-It Mobile** enables you to configure the storage of up to 114 clamps the way you want them, and then put them where you want them, when you want them.

I. ASSEMBLY - BASE & CASTERS

AT THIS POINT YOU WILL NEED:

- ① Base
- ② Rigid Casters (2)
- ③ Swivel Casters (2)
- **HARDWARE BAG**
 - 3/8"-16 x 1" Hex Bolts (16)
 - 3/8"-16 Hex Nuts (16)
 - 3/8" SAE Flat Washers (16)

1. Lay the Base ① on a working surface with the flanges facing down.
2. Place a Rigid Caster ② near one narrow end of the Base with the wheel of the Caster facing inward. **Figure 1.**
3. Place the (4) 3/8" SAE Flat Washers on the (4) 3/8"-16 x 1" Hex Bolts and insert from underneath through the holes in the Base. Place the Rigid Caster over the protruding Hex Bolts.
4. Thread the (4) 3/8"-16 Hex Nuts onto the Hex Bolts, but do not tighten.
5. Repeat for the remaining Rigid Caster.
6. Place a Swivel Caster ③ near the other narrow end of the Base.
7. Place the (4) 3/8" SAE Flat Washers on the (4) 3/8"-16 x 1" Hex Bolts and insert from underneath through the holes in the Base. Place the Swivel Caster over the protruding Hex Bolts.
8. Thread the (4) 3/8"-16 Hex Nuts onto the Hex Bolts, but do not tighten.
9. Repeat for the remaining Swivel Caster.
10. Verify each Caster base is square to the Base and tighten the Kep Nuts in a crossing pattern. Repeat until fully tight.

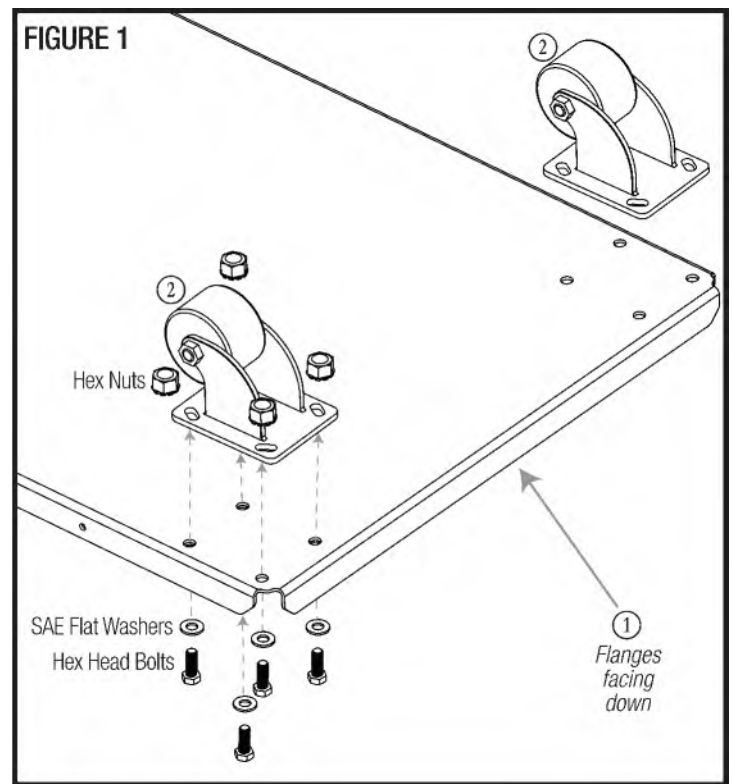

II. ASSEMBLY - SUPPORT & LEGS

AT THIS POINT YOU WILL NEED:

- ④ Legs (2)
- ⑤ Vertical Supports (2)
- **HARDWARE BAG**
 - 1/4-20 x 1/2" Hex Bolts (8)
 - 1/4-20 Kep Nuts (8)

1. Place one Leg ④ on a working surface with the flanges facing down. The bottom of the Leg has 6 slotted holes and the top of the Leg has 8 holes. **Figure 2.**
2. Line up a Vertical Support ⑤ on top of the Leg, near the 6 slotted holes at the end of the Leg.
3. Line up the 4 holes on the Vertical Support with the slotted holes on the Leg.
4. Place (4) of the 1/4-20 x 1/2" Hex Bolts through the top of the slotted holes. **Figure 2-a.**
5. Thread the (4) 1/4-20 Kep Nuts onto the 1/4-20 x 1/2" Hex Bolts and snug slightly.
6. Repeat this process for the other Leg and Vertical Support.

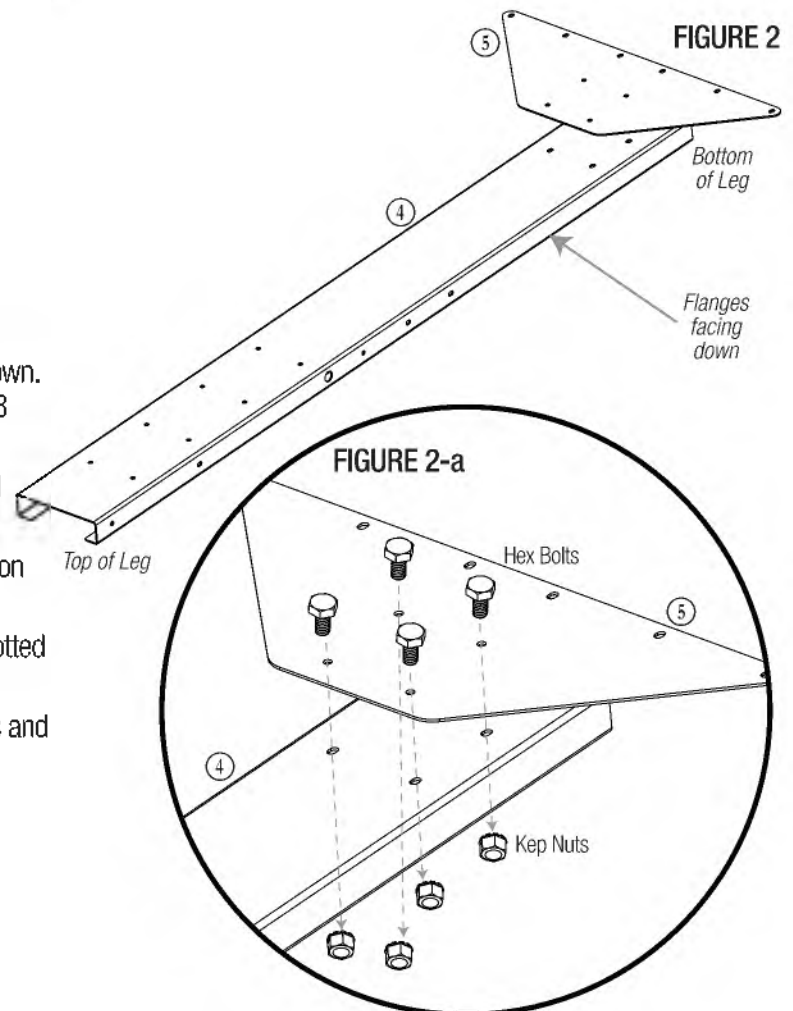

III. ASSEMBLY - HORIZONTAL SUPPORTS

AT THIS POINT YOU WILL NEED:

- ⑥ Horizontal Supports (2)
- **HARDWARE BAG**
 - 1/4-20 x 1/2" Hex Bolts (8)
 - 1/4-20 Kep Nuts (8)

1. Support one Leg Assembly so it will stand on its own.
2. Using (4) 1/4-20 x 1/2" Hex Bolts and (4) 1/4-20 Kep Nuts, attach one end of the Horizontal Support to the Leg Assembly.
Figure 3-a. The top hole on the Horizontal Support will align with the hole in the Leg, and the slotted hole in the Horizontal Support will align with the with a slotted hole in the Leg. **Figure 3.**
3. Attach the remaining Leg Assembly to the other side of the Horizontal Support. **Figure 3-b.**
4. Attached the second Horizontal Support to the opposite side. **Figure 3-c.**

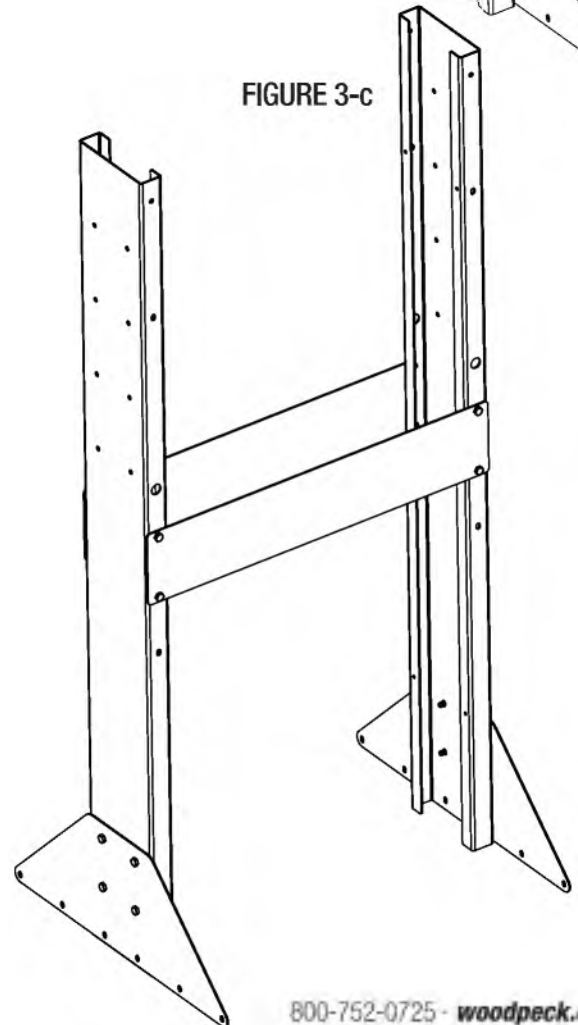
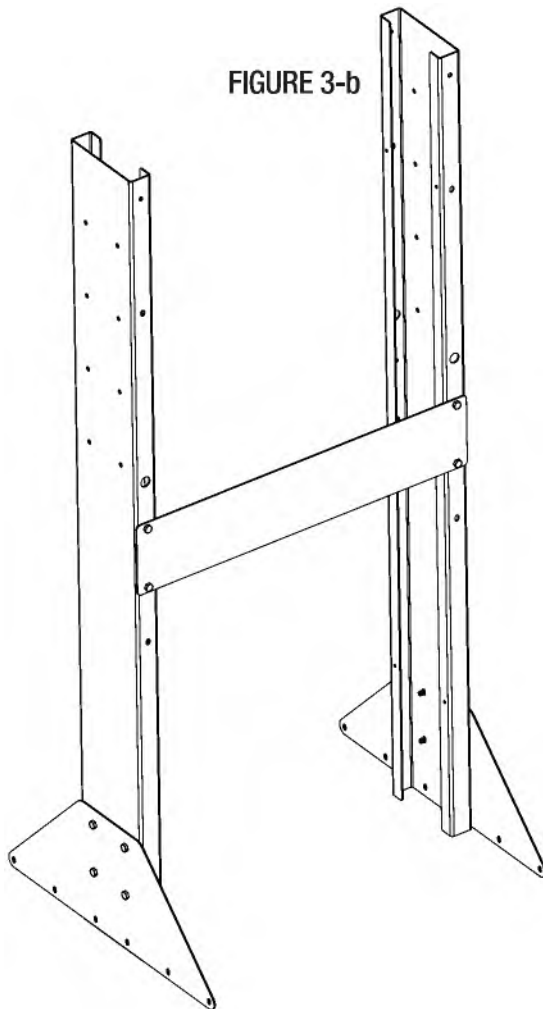
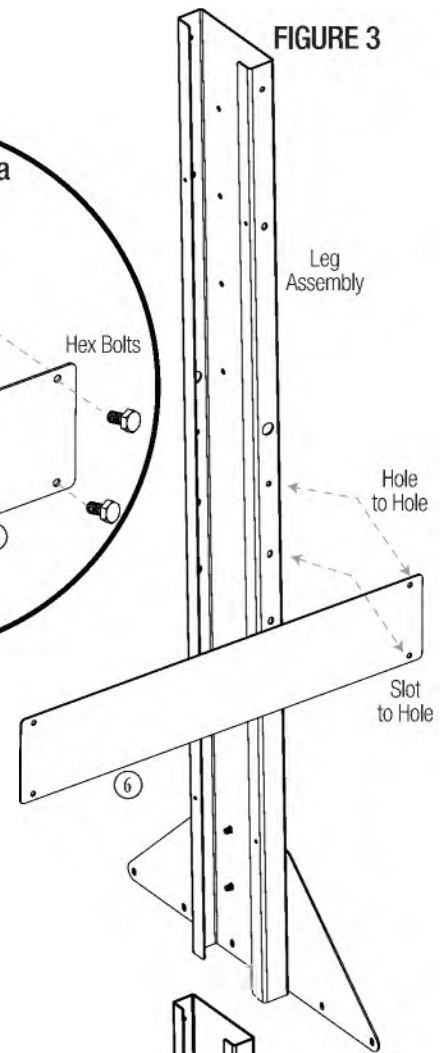
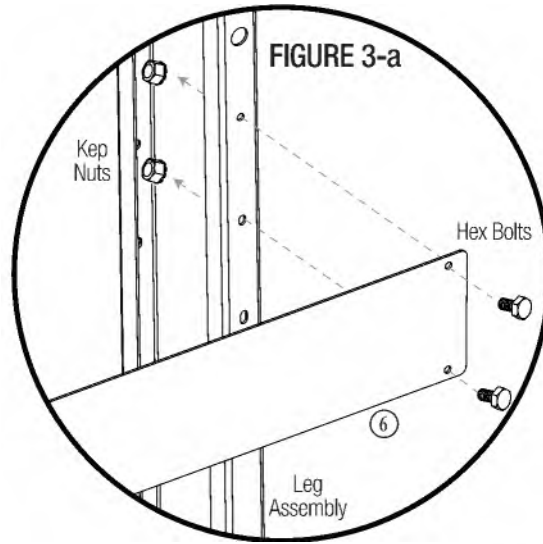

IV. ASSEMBLY - ATTACHING THE LEGS

AT THIS POINT YOU WILL NEED:

- **HARDWARE BAG**

- 1/4-20 x 1/2" Hex Bolts (8)

- 1/4-20 x 3/4" Hex Bolts (4)

- 1/4-20 Kep Nuts (12)

1. Lock the Swivel Casters.
2. With help, lower the Leg Assembly onto the Base.
3. Align the slotted holes on the Vertical Support with the center two holes on the base.
4. Install (4) 1/4 x 20 x 3/4" Hex Bolts into center two holes on each side of the Base through the Vertical Supports/Leg Assemblies and secure with (4) 1/4-20 Kep Nuts. **Figure 4.**
5. Install (8) 1/4-20 x 1/2" Hex Bolts into remaining four holes on each side of the Base through the Vertical Supports and secure with (8) 1/4-20 Kep Nuts.

FIGURE 4

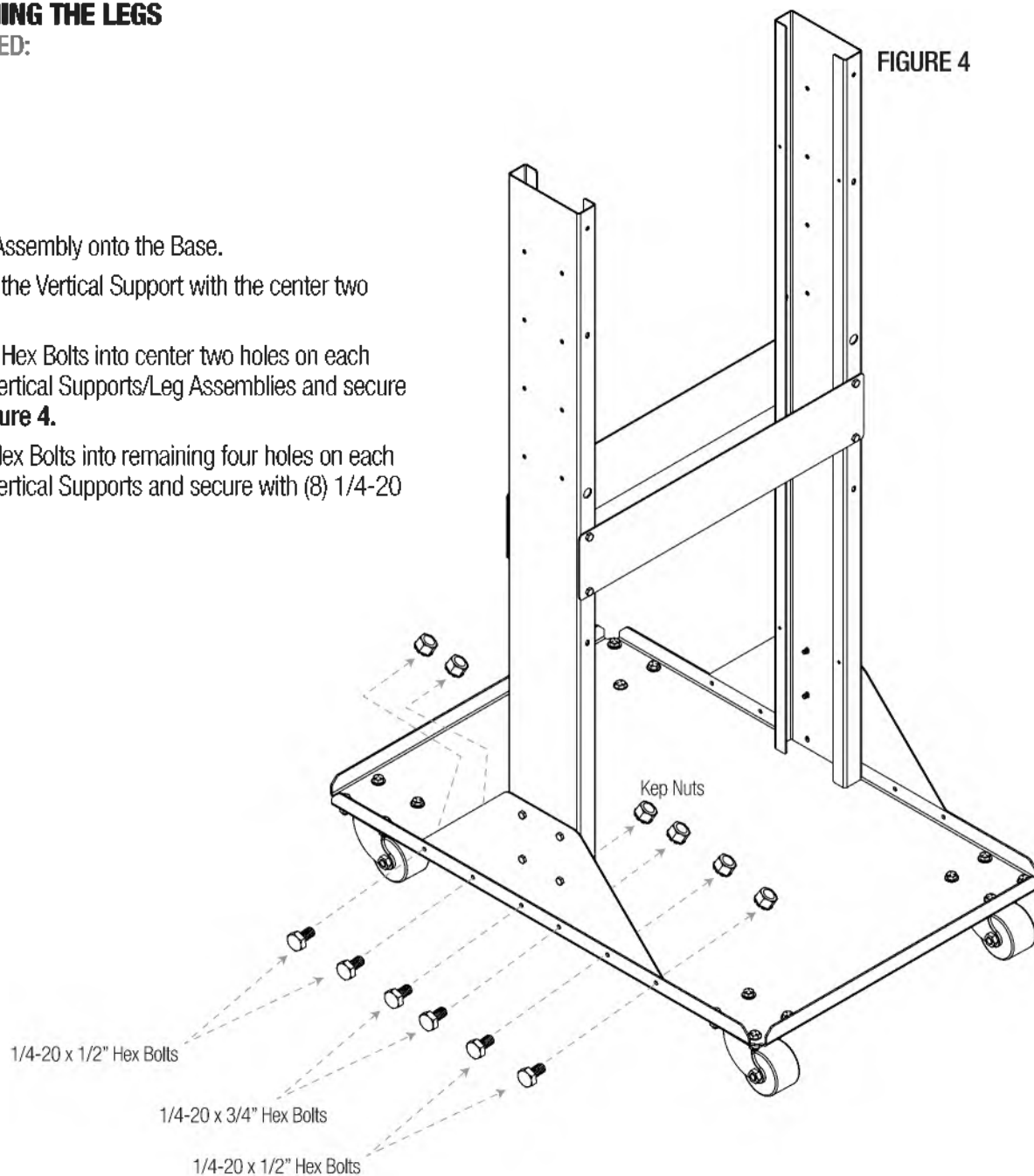

V. ASSEMBLY - CLAMP RACK-IT BACKER PLATES

AT THIS POINT YOU WILL NEED:

- 24" CLAMP RACK-IT SYSTEM

- ⑦ 24" Clamp Rack-It Backer Plate (2)

- **HARDWARE BAG**

- 1/4-20 x 1/2" Hex Bolts (8)

- 1/4-20 Kep Nuts (8)

1. Line up the upper slots of the Clamp Rack-It Backer Plate (with Shelf at the top) with one of the top holes in the Leg. Insert a 1/4-20 x 1/2" Hex Bolt through the Clamp Rack-It Backer Plate and Leg, then secure with a 1/4-20 Kep Nut. Leave it loose. **Figure 5 & 5-a.**

2. Repeat Step 1 on the opposite side of the Clamp Rack-It Backer Plate.

3. Install a 1/4-20 x 1/2" Hex Bolt and 1/4-20 Kep Nut in the bottom slots of the Clamp Rack-It Backer Plate. **Figure 5-a.**

4. Slide the Clamp Rack-It Backer Plate up, and then snug all four 1/4-20 Kep Nut connections.

5. Repeat for the other Clamp Rack-It Backer Plate on the other side of the Legs. **Figure 5-b.**

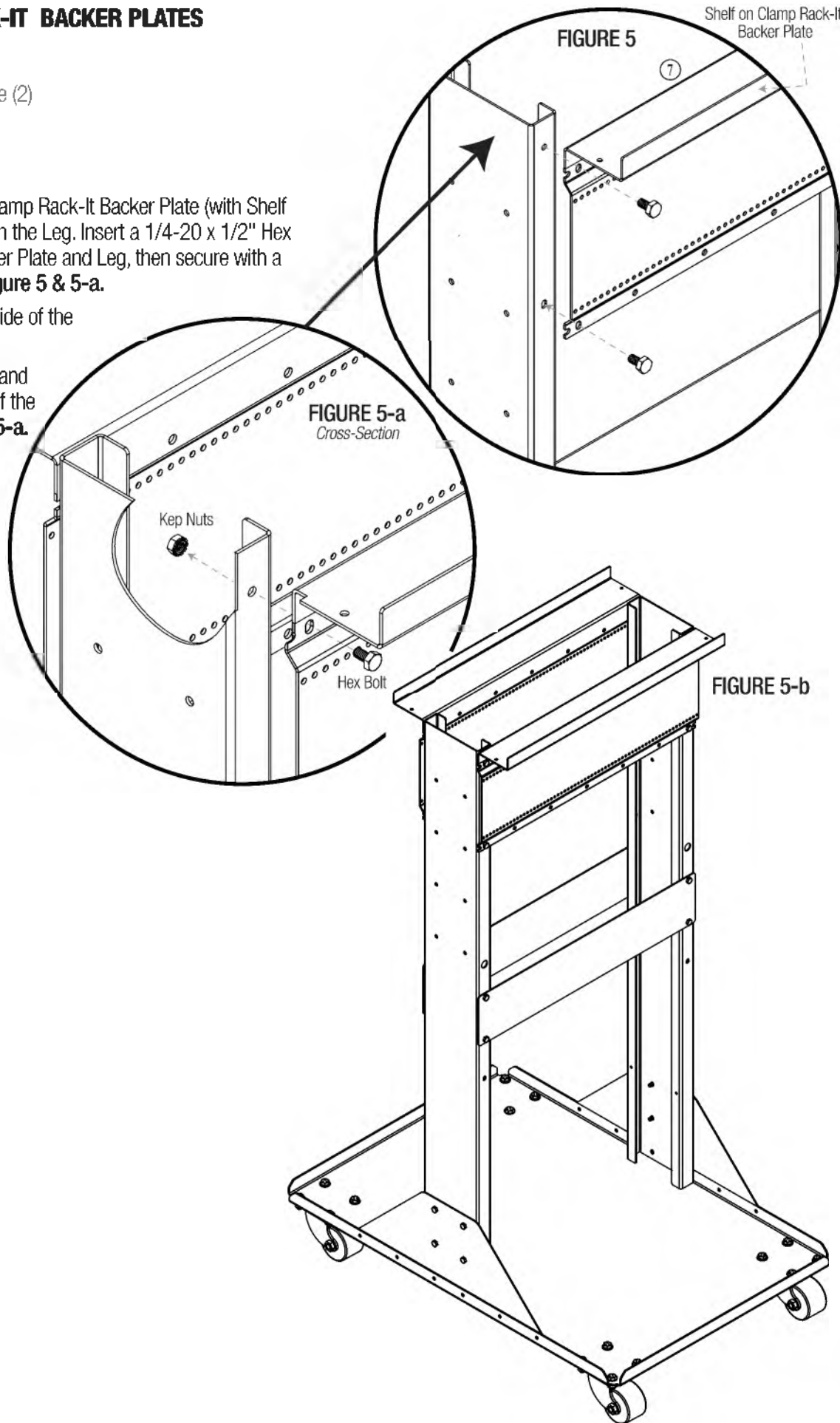

VI. ASSEMBLY - CLAMP RACK-IT ARMS

AT THIS POINT YOU WILL NEED:

- 24" CLAMP RACK-IT SYSTEM

- ⑧ Clamp Rack-It Large Arm Sets (8)
- ⑨ Clamp Rack-It Small Arm Sets (6)
- 10-32 x 3/8" Thread-Forming Screws (56)

NOTE: Installation is the same for both the Clamp Rack-It Large and Small Arm Sets. Measure the width of the bar on your clamp. This will determine the amount of space that is necessary between the left and right Arms to fit your clamps.

1. Identify the Left and the Right Arm of each Clamp Rack-It Arm Set. The lip of the Arms should both face outward to form the rack. **FIGURE 6.**
2. With the location determined, install the 10-32 x 3/8" Thread-Forming Screws for one Arm into the aligning top and bottom hole positions of the Backer Plate. Leave at least an 1/8" gap between the Backer Plate and the Thread-Forming Screw head.
3. Slot the bottom opening of the left Clamp Rack-It Arm around the lower Thread-Forming Screw, then slide the offset keyhole slot over the top Thread-Forming Screw. **FIGURE 7.**
4. Slide the left Clamp Rack-It Arm down so the top of the keyhole slot is resting on the Thread-Forming Screw.
5. Tighten the two Thread-Forming Screws.
6. Leaving the width of your bar clamp in between the left and the right Clamp Rack-It Arm, install the right Clamp Rack-It Arm.
7. Repeat for the other Clamp Rack-It Arms.

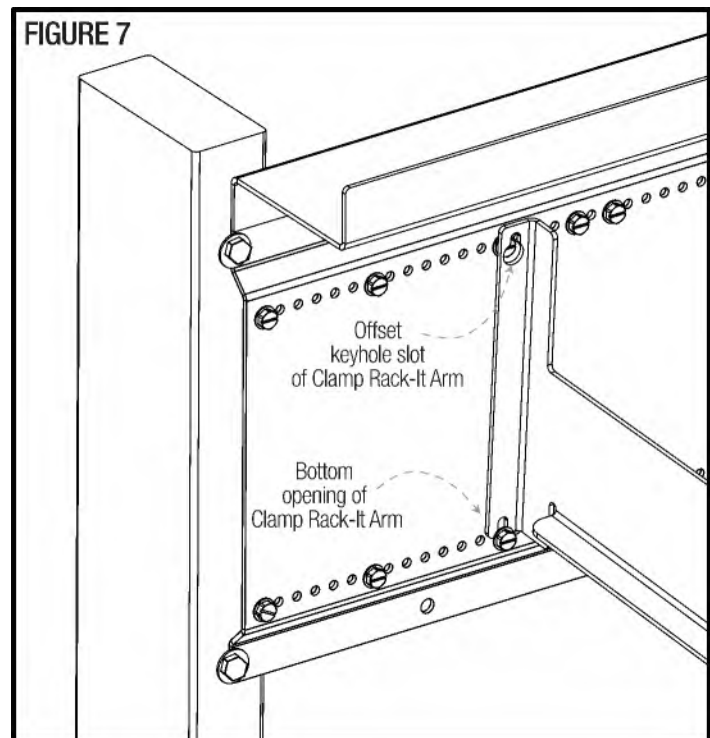
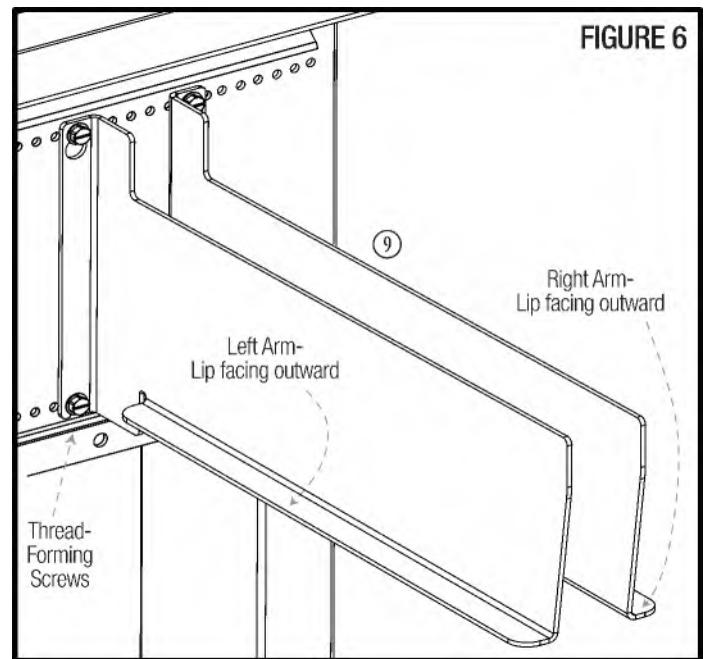

VII. ASSEMBLY - HANDLES

AT THIS POINT YOU WILL NEED:

- ⑩ Handles (2)
- Grips (2)
- D-Washers (4)
- 5/8"-18 Jam Nuts (4)

1. Slide the Handle through the large hole in the Leg Assembly above the Horizontal Supports. At this point do not slide the Handle through the back hole on the Leg Assembly. **FIGURE 8.**
2. Fully thread one of the 5/8"-18 Jam Nuts on to the end of the Handle, but do not tighten. **FIGURE 8-a.**
3. Slide a D-Washer onto the end of the Handle.
4. Slide the Handle through the back hole of the Leg Assembly until the washer bottoms out.
5. On the backside of the Leg Assembly, install a D-Washer and then thread on another 5/8"-18 Jam Nut. **FIGURE 9.**
6. Tighten both 5/8"-18 Jam Nuts, making sure some thread is exposed on the outside.
7. Repeat the process for the other Handle.

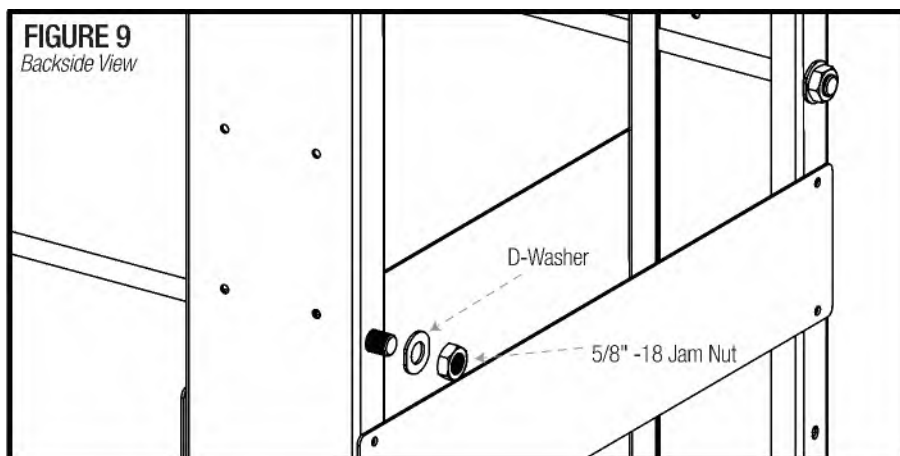
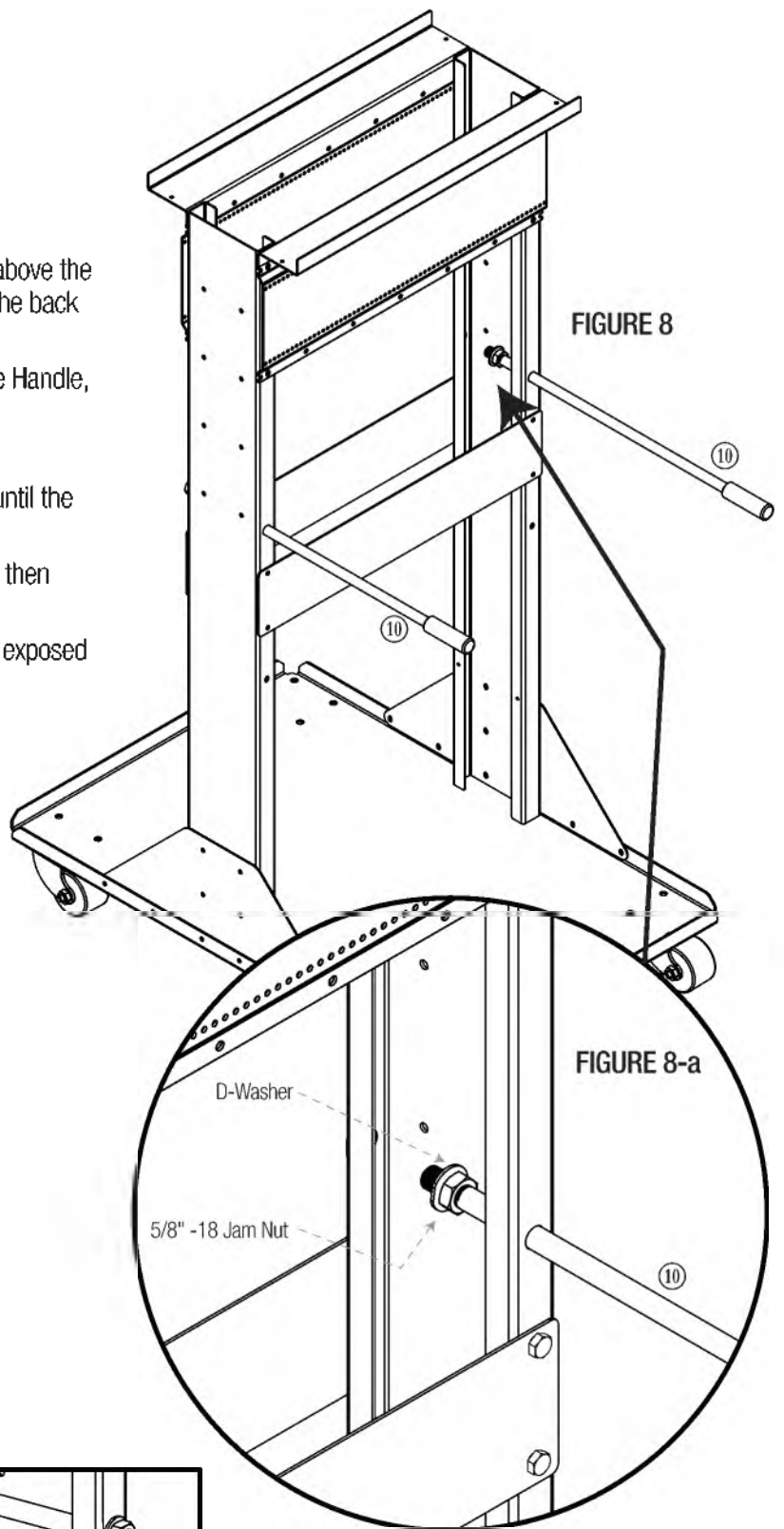



WARNING!



Fully read and understand the instruction book that came with this cart. Save the instruction book for future reference.



Be sure to completely assemble the cart according to the instruction book before using. Be sure that all nuts and bolts are tight before each use.



Do not step, sit or ride on the cart.



Keep the cart out of reach of children. Only capable adults should move or use this cart.



TIPPING HAZARD!

Push the cart using the handles. Never pull the cart. Never pull or push the cart from the top portion or the short dimension of the cart. Use only the handles on the cart to push the cart around.



Keep the cart away from inclines and stairs. This cart will be heavy with clamps installed and may roll easily down any incline.



Lock the swivel castor wheels once the cart is in the chosen location. This will lock from rolling, yet allows the cart to freely spin for use.

Woodpeckers®

PRECISION WOODWORKING TOOLS

Woodpeckers, LLC Strongsville, Ohio · woodpeck.com

© 2019 Woodpeckers, LLC



WARNING! This product can expose you to chemicals, including chromium, which is known to the State of California to cause cancer and birth defects or other reproductive harm. For more information go to www.P65Warnings.ca.gov