

Woodpeckers®

i-DEXABLE® MITER SLED

OWNER'S MANUAL

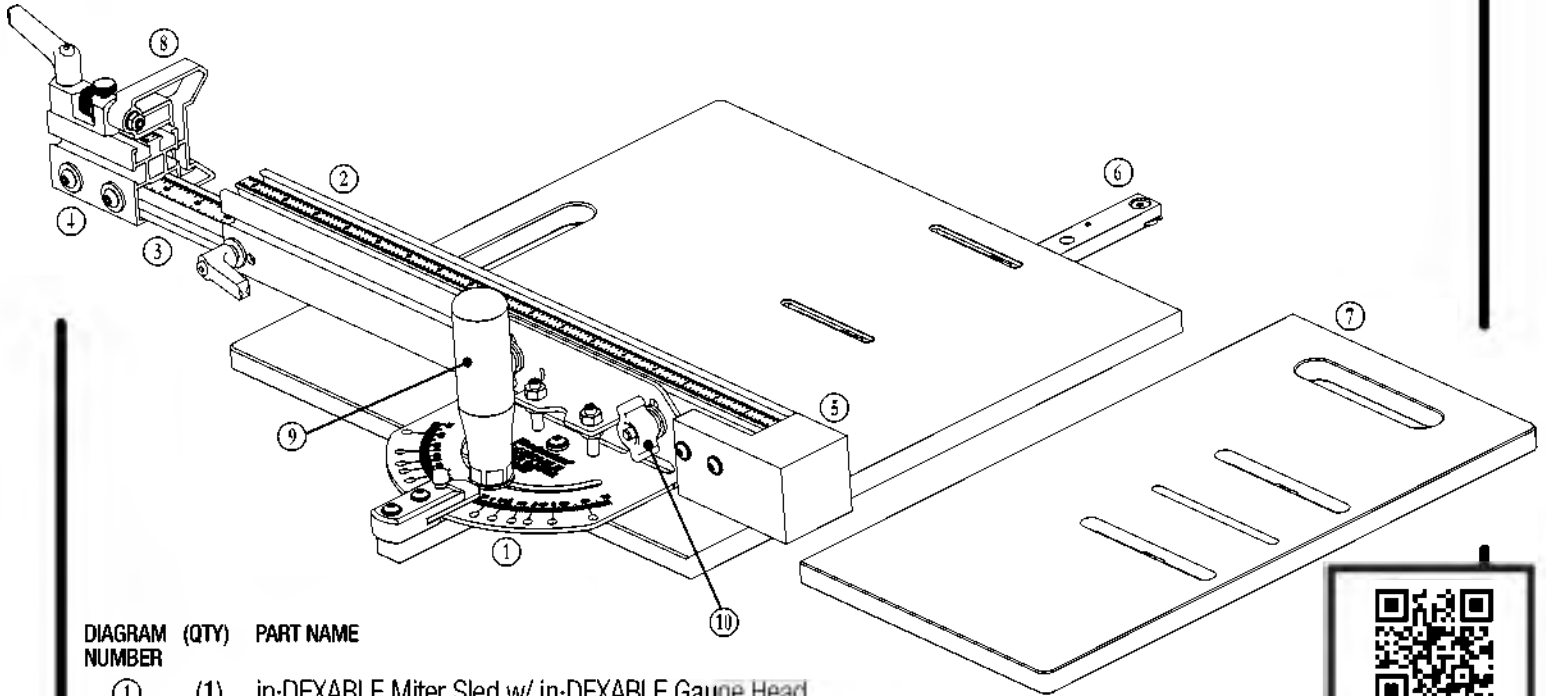

DIAGRAM NUMBER	(QTY)	PART NAME
①	(1)	i-DEXABLE Miter Sled w/ i-DEXABLE Gauge Head
②	(1)	Fence
③	(1)	Fence Extension Slider <i>Shipped inside Fence</i>
④	(1)	Fence Extension
⑤	(1)	Zero Clearance Block
⑥	(1)	Miter Bar w/Nylon Leaf Springs <small>US PATENT NO. 11,958,120</small>
⑦	(1)	Drop Zone Sled
⑧	(1)	Flip Stop w/ Micro-Adjust
⑨	(1)	Clamping Handle
⑩	(2)	Thumb Turn Knobs, 1/4"-20

HARDWARE PACK 1

(QTY)	PART NAME
a	(2) Hex Head Bolt, 1/4-20 x 1"
b	(2) Washer, 1/4"
c	(2) Square Nut, 1/4-20
d	(2) Button Head Cap Screw, 1/4-20 x 1/2"
e	(2) Black Nylon Washer, 1/4"
f	(1) Hex Key, 5/32"
g	(2) Button Head Screw, #10-32 x 7/8"
h	(2) Washer, #10
i	(4) Oval Nut, #10-32
j	(1) Hex Key, 1/8"
k	(2) Flat Head Screw, #10-32 x 5/16"

HARDWARE PACK 2

(QTY)	PART NAME
l	(1) UHMW Strip, Adhesive Backed
m	(3) Button Head Cap Screw, 10-32 x 5/8"
n	(3) Rectangular Washer for #10 Screw

DROP ZONE HARDWARE PACK 3

(QTY)	PART NAME
o	(1) Hex Key, 1/8"
p	(2) Button Head Cap Screw, 10-32 x 5/8"
q	(2) Rectangular Washer for #10 Screw
r	(1) Oval Nut, #10-32
s	(1) Miter Clamping Bar
t	(1) Flat Head Cap Screw, 10-32 x 3/8"
u	(2) Hex Nut, 10-32

OTHER TOOLS YOU MAY NEED Not included

- Woodpeckers® 1281 Woodworking Square *SKU 1281R-24*
- Woodpeckers® Mini Square *SKU MINISQUARE*
- Setup Block
- 7/16" Open-Ended Wrench



Scan the QR code to watch the video or visit woodpeck.com under the video tab towards the bottom of the product page.

If you think you're missing anything, email us at mailroom@woodpeck.com.
You can also call us at 800-752-0725 from 9:00 a.m. to 4:00 p.m. EST Monday - Friday.

I. MITER SLED ASSEMBLY

We calibrate and assemble some components of the in-DEXABLE Miter Sled at the factory. Some fine tuning may be necessary for your saw due to the variety of types and manufacturers. **See Part III, pages 4-6 for Calibration Instructions.**

Unpack all pieces and components to verify you have everything prior to assembly. Note that some items are packed within the cardboard cushions.

► AT THIS POINT YOU WILL NEED:

- ② Fence
- ③ Fence Extension Slider *Shipped inside fence*
- ④ Fence Extension
- ⑧ Flip Stop w/ Micro-Adjust

• HARDWARE PACK 1

- c Square Nut, 1/4-20
- d Button Head Cap Screw, 1/4-20 x 1/2"
- e Black Nylon Washer, 1/4"
- f Hex Key, 5/32"

• HARDWARE PACK 2

- l UHMW Strip, Adhesive-Backed

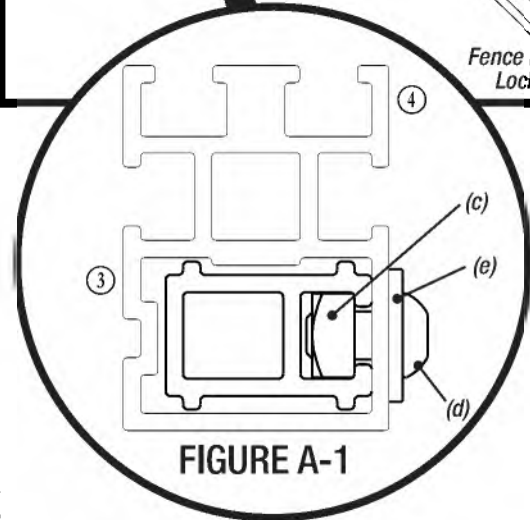
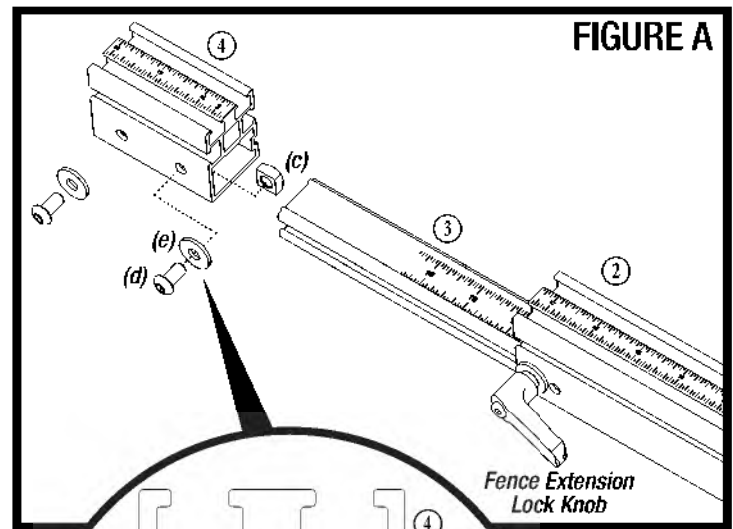

1. FENCE ASSEMBLY

- a. Align and loosely thread 2 Button Head Cap Screws(d) and 2 Black Nylon Washers(e) through the pre-drilled holes in the Fence Extension④ and into the 2 Square Nuts(c). **Do not tighten.** **FIGURE A.**
- b. The Fence Extension Slider③ ships inside the Fence②. Loosen the Fence Extension Lock Knob and slide the Fence Extension Slider outward a few inches.
- c. Guide the Square Nuts(c) into the slot on the rear side of the Fence Extension Slider. **FIGURE A-1.**
- d. Flush the ends of the Fence Extension and Fence Extension Slider with a flat piece of scrap wood. Lock into place by tightening the 2 Button Head Cap Screws(d) using the Hex Key(f).
- e. Turn the Fence Assembly upside down and install the UHMW Strip(l) on the underside of the Fence only, stopping before the Fence Extension. Trim any excess.
- f. Install the Flip Stop⑧ by guiding the Square Nut(c) into the rear slot of the Fence Track. **FIGURE B.**
 - TO LOOSEN, spin the Ratcheting Lock Knob counter-clockwise.
 - TO LOCK it in place, spin the Ratcheting Lock Knob clockwise.

FIGURE B

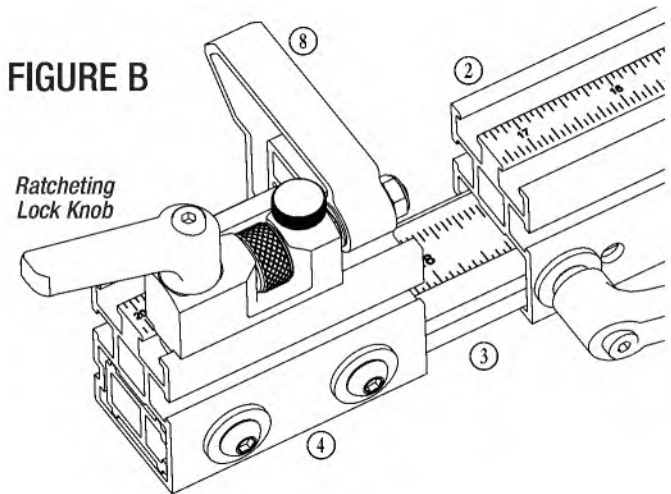

NOTE

The Ratcheting Lock Knob on the Micro-Adjustable Flip Stop may be lifted up and spun to eliminate interference with the flag.

▶ AT THIS POINT YOU WILL NEED:

- ① in-DEXABLE Miter Sled w/ in-DEXABLE Miter Gauge Head
- ⑤ Zero Clearance Block
- ⑥ Miter Bar w/Nylon Leaf Springs
- ⑨ Clamping Handle
- ⑩ Thumb Turn Knobs, 1/4"-20

• HARDWARE PACK 1

- a Hex Head Bolt, 1/4-20 x 1"
- b Washer, 1/4"
- g Button Head Screw, #10-32 x 7/8"
- h Washer, #10
- i Oval Nut, #10-32
- k Flat Head Screw, #10-32 x 5/16"

• HARDWARE PACK 2

- n Button Head Cap Screw, 10-32 x 5/8"
- m Rectangular Washer for #10 Screw
- o Hex Key, 1/8"

2. MITER HEAD ASSEMBLY

- a. The Miter Gauge Head ① ships with a temporary knob in place of the Clamping Handle ⑨. Remove and replace with the Clamping Handle. **FIGURE C.**
- b. Install a Hex Head Bolt (a), Washer (b), and Thumb Turn Knob ⑩ into each of the mounting slots on the Miter Gauge Head. **FIGURE C.**
- c. Slide the Fence onto the Hex Head Bolts in the Miter Head and secure in place with the Thumb Turn Knobs. **FIGURE D.**
- d. The Miter Sled attaches to the Miter Bar ⑥ through slots that accommodate the distance between the miter slot and the saw blade of most table saw designs.
- e. Place a Rectangular Washer (m) onto a Button Head Screw (n) and thread into the holes in the Miter Bar. *At this point in time, the screws only need to be threaded in a couple of turns.* **FIGURE D-1.**
- f. Turn the Miter Sled upside down. Align the Rectangular Washers with the oval cutouts in the sled, and drop them in. **FIGURE E.**
- g. Once all 3 Washers and Button Head Screws have dropped into the slots, slide them to the middle of the Track. Flip the Sled right side up. Tighten the Button Head Screws into the Miter Bar until they are just snug enough to keep the bar from sliding. Calibration of the Miter Bar to your saw will be done later. **FIGURE E.**
- h. There are 2 Oval Nuts (i) you can install if your table saw miter slot has a T-shaped profile. **FIGURE D-2.**
- i. To install, place an Oval Nut into the cutout, with the raised side facing the hole, then install a Flat Head Screw (k) into the countersink on the other side of the Miter Bar. Tighten fully using the Hex Key (o).
- j. One Zero Clearance Block ⑤ is included. This MDF block helps push the offcut past the blade and prevents tear out on the backside of the cut. To install the Zero Clearance Block, pre-install the Button Head Screws (g), Washers (h), and Oval Nuts (i) into the block, then slide into the rear slot of the Fence Track. **FIGURE F.**

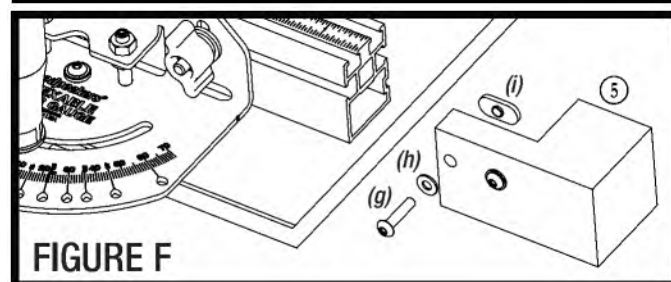
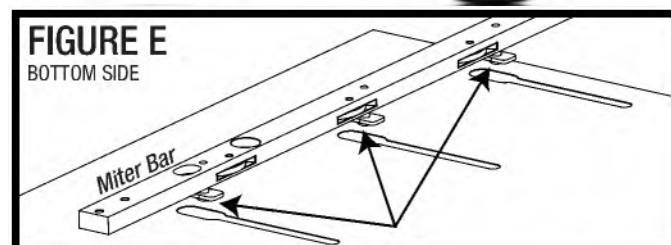
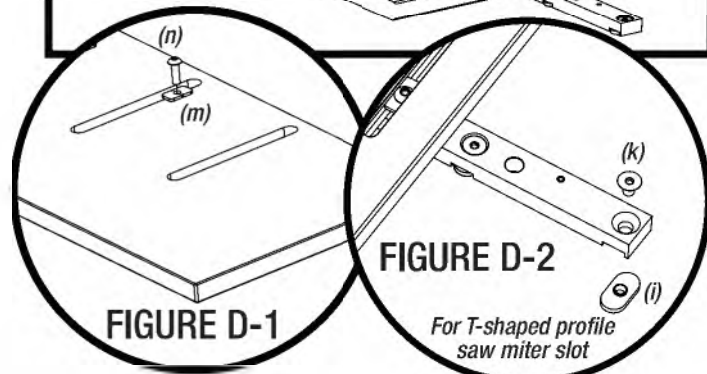
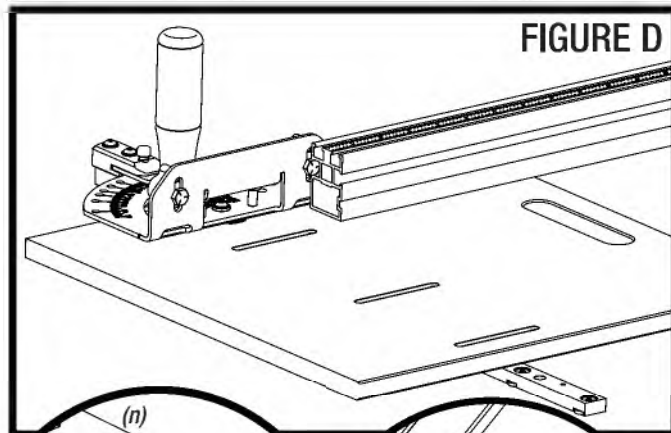
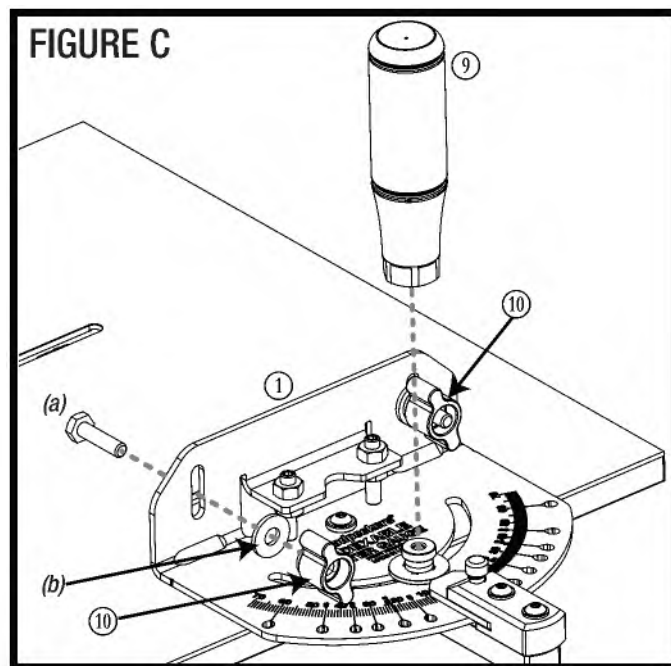

II. INITIAL SETUP & CALIBRATION

You can either align the existing edge of the Sled to your blade or for perfect zero clearance you can take a skim cut off the edge of the Sled. The choice is yours. The protractor on the Miter Gauge Head has been calibrated to the factory edge, but in the procedure below you can calibrate it to a freshly sawn edge.

- A. For either method, begin by loosening the Button Head Screws holding the Sled to the Miter Bar. Slide the Sled until it aligns with your saw blade (or just slightly beyond, if you are going to cut a fresh edge). **FIGURE G.**
- B. To verify factory calibration or calibrate to a fresh edge, loosen the Clamping Handle. Set a known square reference (such as a Woodpeckers® 1281 Square) on the Sled edge. Align the Fence to the square. **FIGURE H.**
- C. Tighten the Clamping Handle to lock in this angle.
- D. Make a test cut to confirm the calibration. Adjust until a test cut delivers a square cut.

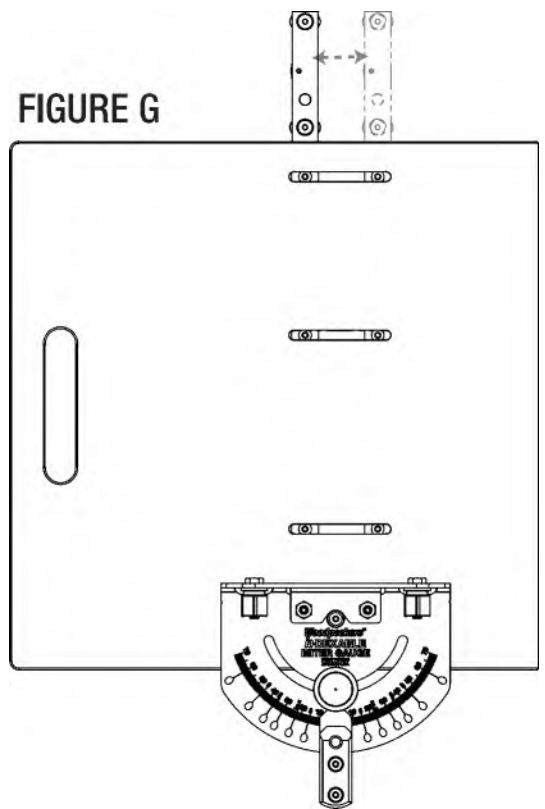

1. CALIBRATING THE MITER ANGLE

Once the Fence is delivering square cuts, the Angle Detent Bar and lens can be calibrated.

- a. Crack loose the 2 Button Head Cap Screws on the Angle Detent Bar using the 1/8" Hex Key.
- b. While pressing the Angle Detent Button, wiggle the Angle Detent Bar until the Pin drops into the Detent.
- c. With the Angle Detent Button still depressed, adjust the Angle Detent Bar until the Hairline Indicator Lens aligns with the engraved "0" line and tighten the 2 Button Head Cap Screws. **FIGURE I.**
- d. Check the calibration by loosening the Handle, rotating the Miter Head, and re-engaging the 0° detent. Check the setting again using your reliable square reference. Repeat the adjustment as necessary to your desired accuracy. **FIGURE I-1.**

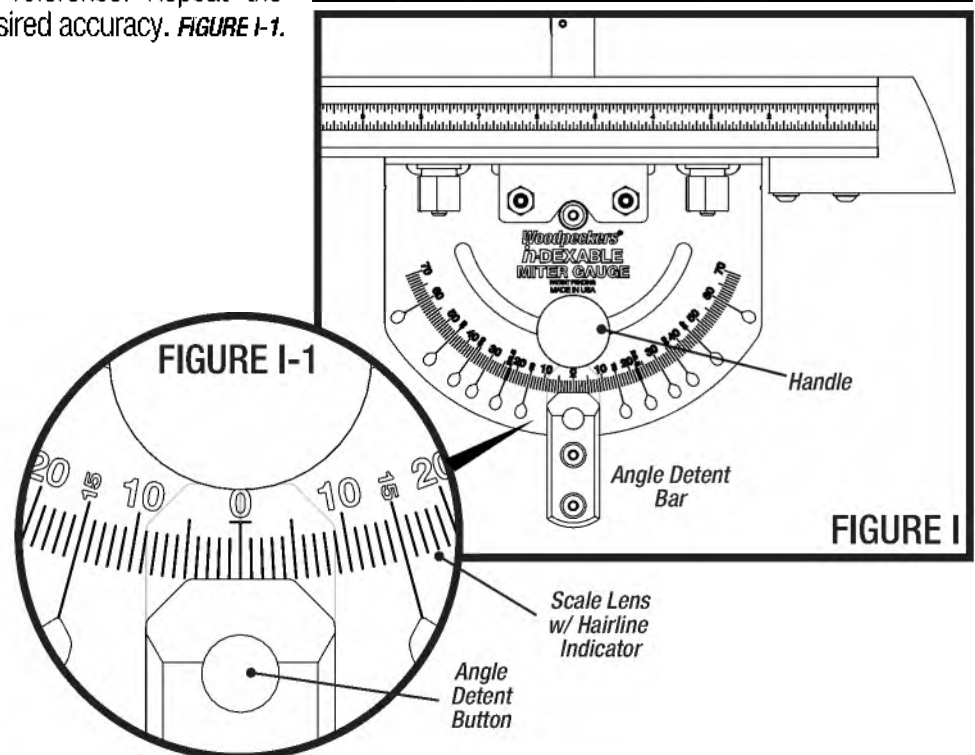
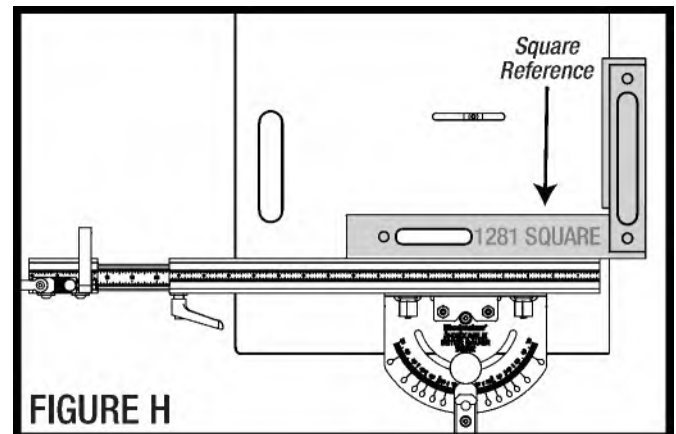

III. CALIBRATION

1. CALIBRATING THE FENCE SCALE

- Begin by retrieving a reliable setup block with a known thickness (such as Woodpeckers® Setup Blocks or a high quality drill bit). Set your Flip Stop to that same dimension on the Scale, using the Micro-Adjust to split the line.
- Unplug your table saw and raise the blade about two inches above the table. Place the in-DEXABLE Miter Gauge in your miter slot.
- Loosen the 2 Thumb Turn Knobs on the Miter Head. With the setup block between the Flip Stop and the teeth of the saw blade, adjust the Fence laterally so the setup block just barely touches both the tooth and the flag. You should feel contact on both sides of the setup block, but it should not be pinched. **FIGURE J.**
- Lock the Fence in place by tightening the Thumb Turn Knobs.
- Set the Scale at a dimension of your choice and make a test cut to verify accurate calibration. If Adjustments are needed, repeat these steps.

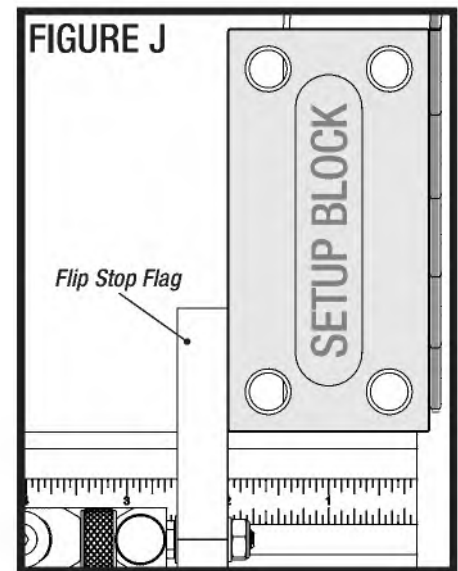

PRO TIP

For the Inch version, the Flip Stop Flag is exactly 1/2" thick. Set the left side of the flag to the 1/2" dimension and adjust the Fence so the right side of the Flag kisses the saw blade tooth.

2. CALIBRATING THE EXTENSION SLIDER SCALE

The Extension Slider Scale is designed to be accurate when the end of the Fence Extension is flush with the Slider, but some fine adjustment may be necessary.

- Begin by setting the Flip Stop with the right side of the Flip Stop Flag set to the Scale line marked "EXT" and using the Micro-Adjust to split the line.
- Extend the Fence to your desired dimension and make a test cut to verify accurate calibration.
- If adjustments are necessary, adjust the position of the Fence Extension by loosening the 2 Button Head Cap Screws with the 5/32" Hex Key. Repeat steps as necessary.

3. CALIBRATING THE FENCE ROLL ANGLE

We calibrate the fence roll angle on your in-DEXABLE Miter Sled perpendicular to the Sled Base at the factory. However, adjustments may be necessary for your saw.

- Begin by retrieving a reliable square reference (Woodpeckers® Mini Square) and place your in-DEXABLE Miter Sled in your miter slot. **FIGURE K.**
- To check for square, place the reliable square on the table and against the front face of the Fence.
- Use a 7/16" open-ended wrench (not included) to crack loose the upper Hex Nuts on the Jack Screw assemblies. Loosen a few turns to give room for adjustment.
- Place the 7/16" wrench onto the lower Hex Nuts and the 1/8" Hex Key into the socket of the Jack Screw.
- Prevent the Jack Screw from turning with the Hex Key and use the wrench to tighten or loosen the lower Hex Nut to adjust the roll angle. Do so until the reference square touches at both top and bottom of the Fence.
- Repeat for the other Jack Screw.
- Once satisfied with the setting, ensure the lower Hex Nuts are snug against the flanges and tighten the upper Hex Nuts to lock the setting in place. Again, use the 1/8" Hex Key to prevent the Jack Screws from spinning.

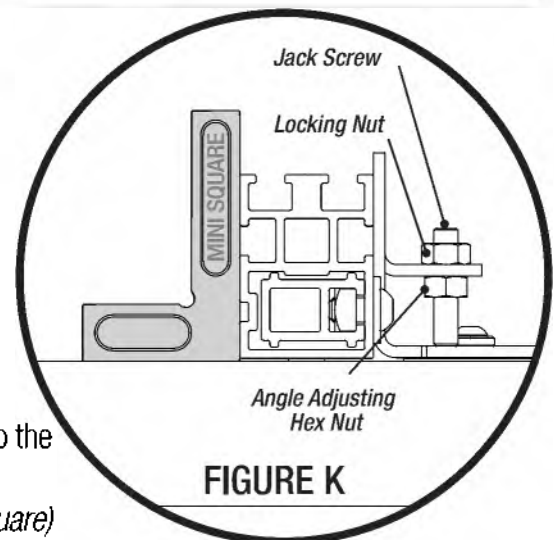
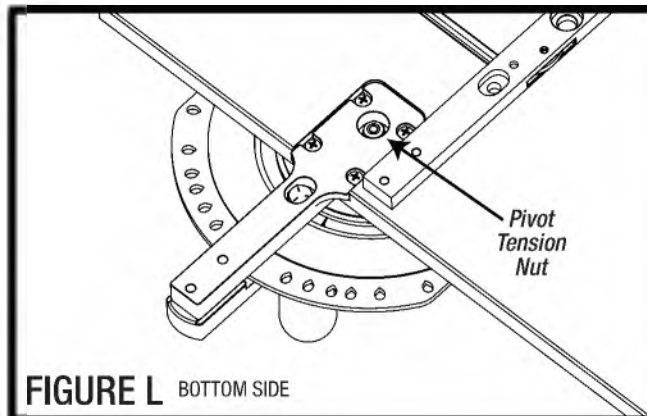

FIGURE K

4. ADJUSTING MITER HEAD PIVOT TENSION

- To adjust the pivot tension, flip the Miter Sled upside-down and locate the Nylon Lock Nut on the underside of the Miter Head Pivot. **FIGURE L**
- Using a 3/8" hex socket (*not included*), tighten or loosen the nut to set your desired tension. Only a very minor amount of adjustment should ever be required.



IV. USING THE IN-DEXABLE MITER GAUGE

1. ADJUSTING THE ANGLE USING THE SCALE

- Loosen the Handle by turning it counter-clockwise. Use the Fence to rotate the Miter Gauge Head and adjust to the desired dimension. **FIGURE M**.
- The angle is read through the Hairline Indicator on the Scale Lens. **FIGURE M-1**.
- When adjusted to your desired setting, tighten the Handle firmly.

NOTE Do not loosen the Button Head Cap Screw on the top side of the Miter Head Pivot, which is intended to be a permanent connection. Loosening the Button Head Cap Screw will invalidate angle calibration.

2. ADJUSTING THE ANGLE USING THE ANGLE DETENTS

- Loosen the Handle by turning it counter-clockwise. Use the Fence to rotate the Miter Gauge Head and roughly locate the Miter Gauge Head near the desired detent.
- While pressing the Detent Button, rotate the Miter Gauge Head until the Pin snaps into the detent.
- While continuing to press the Detent Button, tighten the Handle firmly to secure the setting.

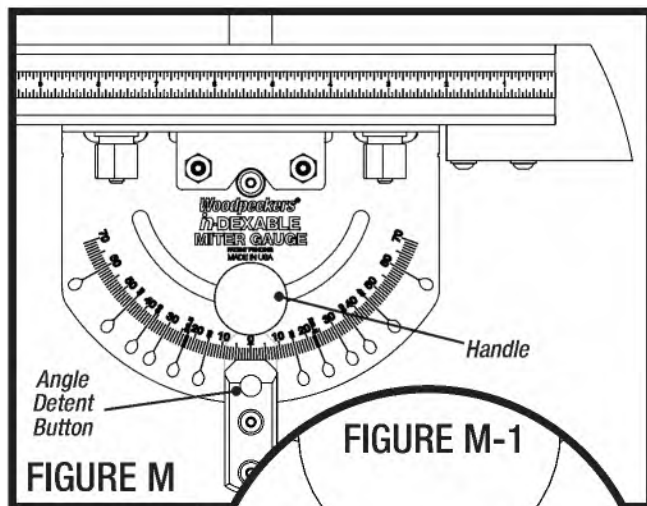

3. USING THE FENCE & FENCE EXTENSION

- The Fence can be adjusted laterally for beveled cuts or for calibrating the Scale to the blade. Adjust the Fence by loosening the 2 Thumb Knobs, moving the Fence, and re-tightening the Thumb Knobs. Always check the full path of travel to ensure no contact with the blade.
- The Fence can be extended for additional workpiece support. To extend the Fence, loosen the Fence Extension Lock Knob, slide the Fence Extension Slider out, and tighten the Fence Extension Lock Knob. **FIGURE N**.
- To use the Scales on the Fence Extension, begin by setting the Flip Stop A so that the right side splits the scale line marked "EXT" (17-5/8" on the inch version and 445mm on the metric).
- The Extension Scale now reads at the end of the Fence. **FIGURE N-1**.

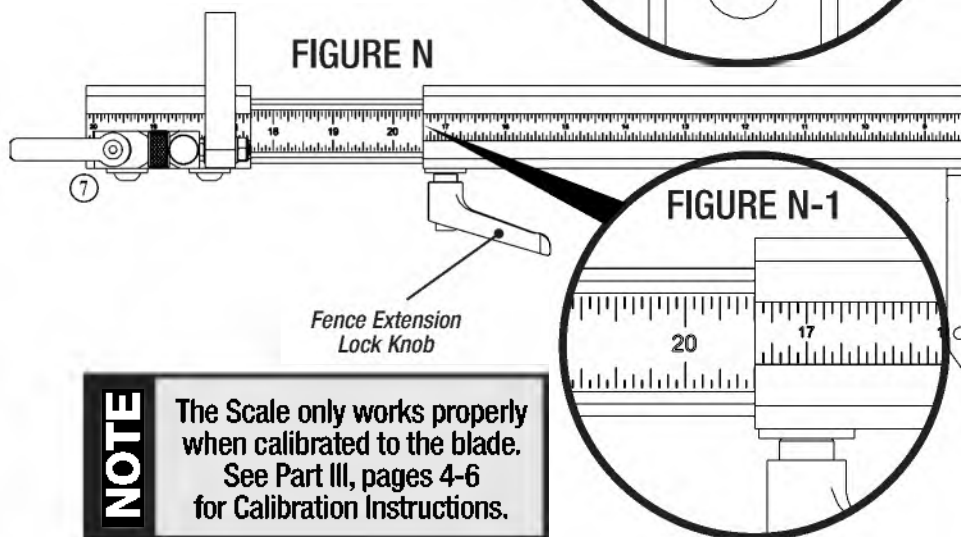

NOTE The Scale only works properly when calibrated to the blade. See Part III, pages 4-6 for Calibration Instructions.

4. USING THE FLIP STOP

- The Flip Stop can be located anywhere along the fence for repeatable cuts. Loosen the Locking Knob, set the stop at the desired cut length and re-tighten the Locking Knob. **FIGURE O.**
- Use the thumb-wheel on the Micro-Adjust to fine tune the cut length and the small Thumb Screw to secure the Micro-Adjust setting. **FIGURE O-1.**

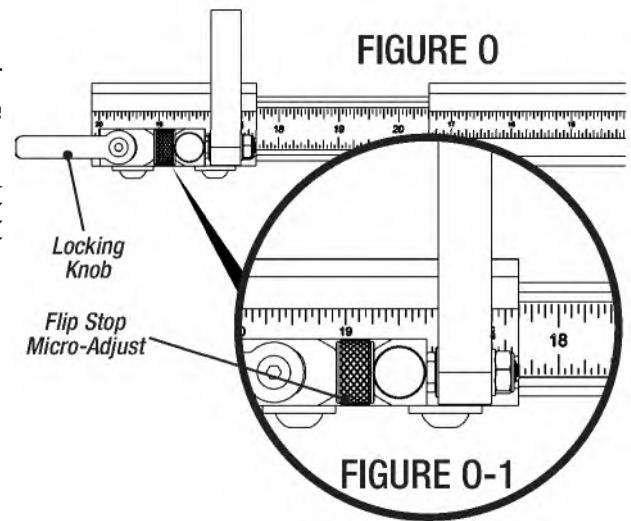

V. DROP ZONE ASSEMBLY & USE

▶ AT THIS POINT YOU WILL NEED:

⑦ Drop Zone Sled

• HARDWARE PACK 3

- o Hex Key, 1/8"
- p Button Head Cap Screw, 10-32 x 5/8"
- q Rectangular Washer for #10 Screw
- r Oval Nut, #10-32
- s Miter Clamping Bar
- t Flat Head Cap Screw, 10-32 x 3/8"
- u Hex Nut, 10-32

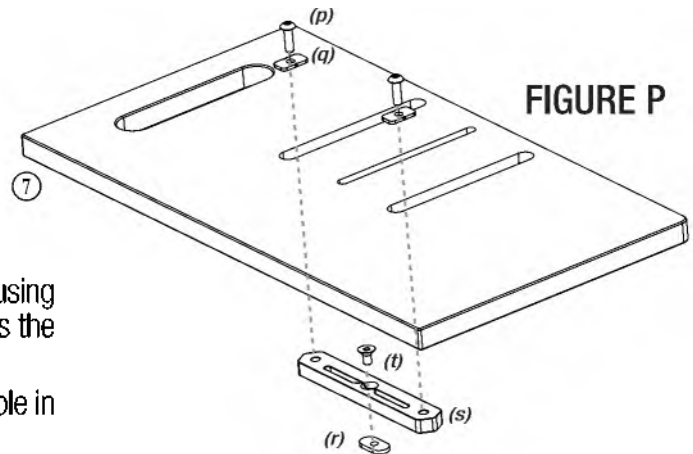

- The Drop Zone Sled (7) is a platform for catching offcuts when using the in-DEXABLE Miter Sled. It is made of the same material and is the same thickness as the Miter Sled Base.
- Install the Oval Nut (r) and Flat Head Cap Screw (t) into the center hole in the Miter Clamping Bar (s) **FIGURE P.**
- Install a Hex Nut (u) into each of the hex pockets in the Miter Clamping Bar.
- Place a Rectangular Washer (q) onto a Button Head Screw (p) and place into the recessed slots of the Drop Zone. Tighten the screw into the Miter Clamping Bar in both locations.
- The location of the Drop Zone edge relative to the table saw blade is adjustable within the recessed slot by loosening the Button Head Screws and moving the Sled to the desired location.
- The Clamping Miter Bar fits in a standard miter slot, and is locked in place by tightening the Flat Head Screw (t) from above using the Hex Key (o).

VI. IN-DEXABLE MITER GAUGE CONVERSION

1. The in-DEXABLE Miter Gauge can be upgraded to an in-DEXABLE Miter Sled and vice versa. An upgrade kit is available for any in-DEXABLE Miter Gauge owners. (SKU: SSCMS-UP). An in-DEXABLE Miter Sled can be converted back into an in-DEXABLE Miter Gauge if desired.
2. Begin by installing the Miter Sled Pivot Bar into the Sled. It should be a snug fit. Secure with the 4 Wood Screws. Do not over-tighten the Wood Screws.
3. Partially disassemble the Miter Gauge, starting with removing the fence. Next, remove the Index Bar assembly by loosening the 2 Button Head Screws. **FIGURE Q.**
4. Take off Clamping Handle, Washer, and Hex Head Bolt.
5. Loosen and remove the Pivot Tension Nut and Washer, using a 3/8" socket (not included). **NOTE:** Do not loosen the Button Head Screw opposite the Pivot Tension Nut.
6. Remove the Miter Head assembly from the Miter Bar.
7. Install Miter Head assembly into the Sled Pivot Bar, then install Pivot Tension Nut and Washer. Adjust to desired pivot tension. **FIGURE R.**
8. Install the Clamping Handle, Hex Head Bolt, and Washer.
9. Install the Index Bar assembly.
10. Once everything is re-installed on the Sled, follow the instructions at the start of the manual as if you were unpacking and setting up the tool for the first time. **NOTE:** you will need to calibrate both the miter angle and roll angle as described in the **III. Calibration Sections (pages 4-6).**
11. To convert the Miter Sled to a Miter Gauge, follow the directions in reverse, and re-calibrate miter and roll angles when complete.

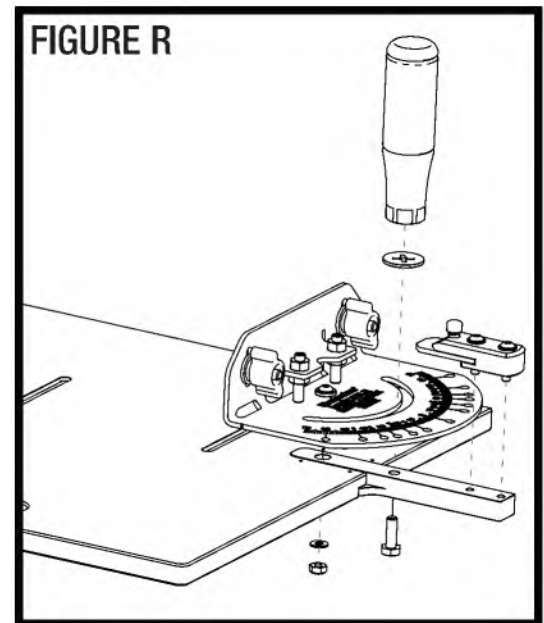
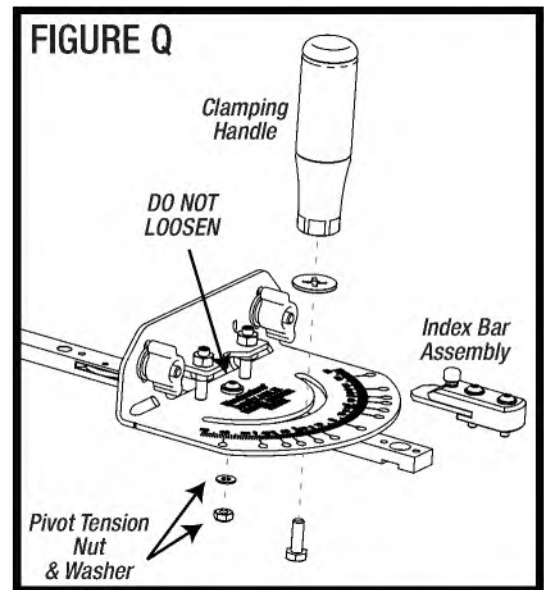

WARNING! To reduce the risk of injury keep hands away from moving parts. Refer to your power tool manual for proper setup and use.



WARNING! To reduce the risk of injury, wear safety goggles or glasses with side shields, ear protection & a dust mask.

Woodpeckers®

Woodpeckers, LLC Strongsville, Ohio
woodpeck.com
 © 2026 Woodpeckers, LLC



At Woodpeckers we are constantly reviewing & improving our tools. The most current version of our instruction manuals are always available to download at **woodpeck.com**.
 (Located in the bottom section of the tool's page under the "Additional Information" or "instructions" tabs.)



Be the first to know all the new products, **OneTIME Tools & sales** by subscribing to our eClub. (Located at the top center of our webpage **woodpeck.com**.)



Subscribe to our YouTube channel to stay up-to-date on all the latest tool tips & tricks.



INTERACT WITH US! Follow us on Facebook, Instagram & TikTok!



Enjoy shop tips, project ideas, tool techniques & more in our Woodworking Resource Center/Blog. (Located at the bottom center of our webpage **woodpeck.com**.)



WARNING!

This product can expose you to chemicals, including chromium, which is known to the State of California to cause cancer and birth defects or other reproductive harm.

For more information go to www.P65Warnings.ca.gov