

# Woodpeckers®

## JOINERY SLED

### OWNER'S MANUAL

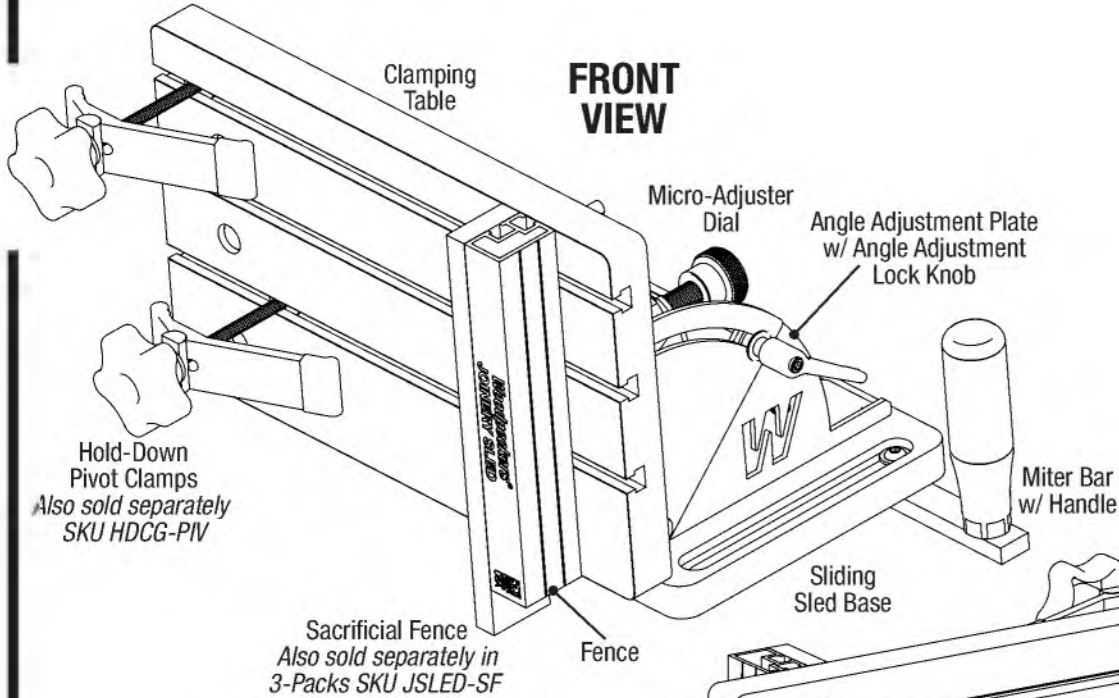

#### HARDWARE

- 5/32" Hex Key
- 1/8" Hex Key
- 3/16" Hex Key
- ① Weld Nut
- ② 2" Set Screw
- ③ 1/4-20 Hex Head Bolt
- ④ Button Head Screws

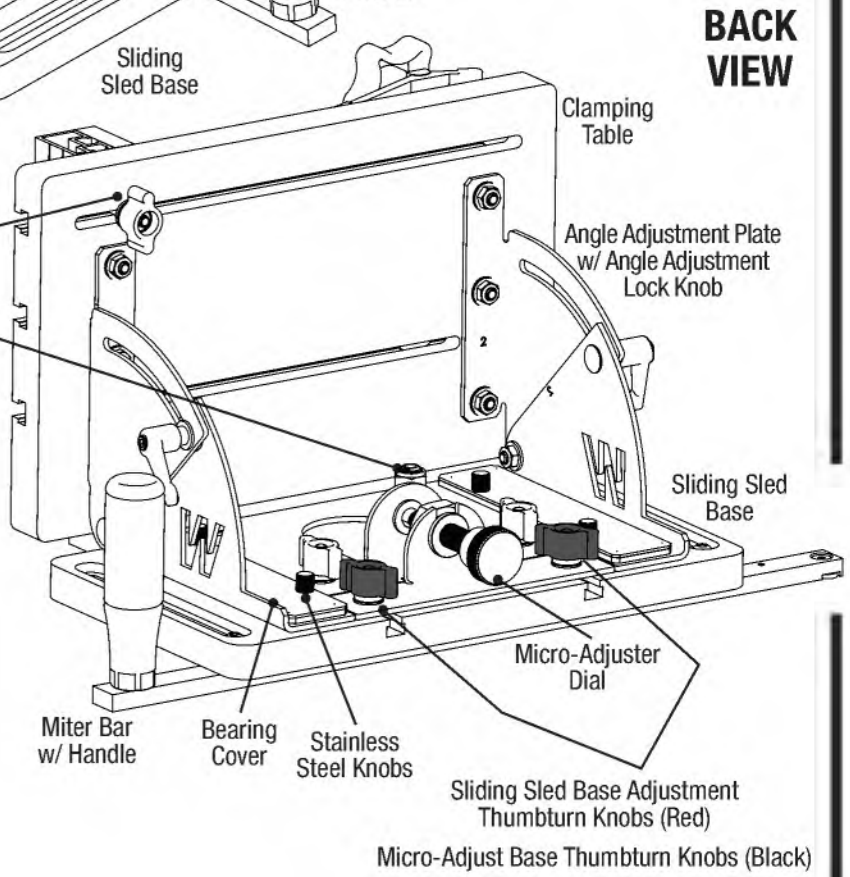

**THANK YOU** for your purchase of the **Woodpeckers Joinery Sled**. Cutting precise joinery at the router table or table saw is now safer and more accurate and complex joints are easier than ever.

The Joinery Sled is designed to be easily calibrated to the cut at hand, precisely positioning your workpiece while guiding it past the cutter. The angle adjustment overcomes any minor inconsistencies in machinery setups, for flawless, tight-fitting joinery that will last a lifetime.

**Quick Start Guide**.....2

**Detailed Assembly & Calibration**..... 3-6

**Get to Know Your Joinery Sled**.....7

**Additional Accessories**..... 8



Scan the QR code to watch the video or visit [woodpeck.com](http://woodpeck.com) under the video tab towards the bottom of the product page.

If you think you're missing anything, email us at [mailroom@woodpeck.com](mailto:mailroom@woodpeck.com).  
 Check the product page under the "Manuals" tab for an up to date version of this manual.  
 You can also call us at 800-752-0725 from 9:00 a.m. to 4:00 p.m. EST Monday - Friday.

# QUICK START

## Install the Sliding Base Bearings

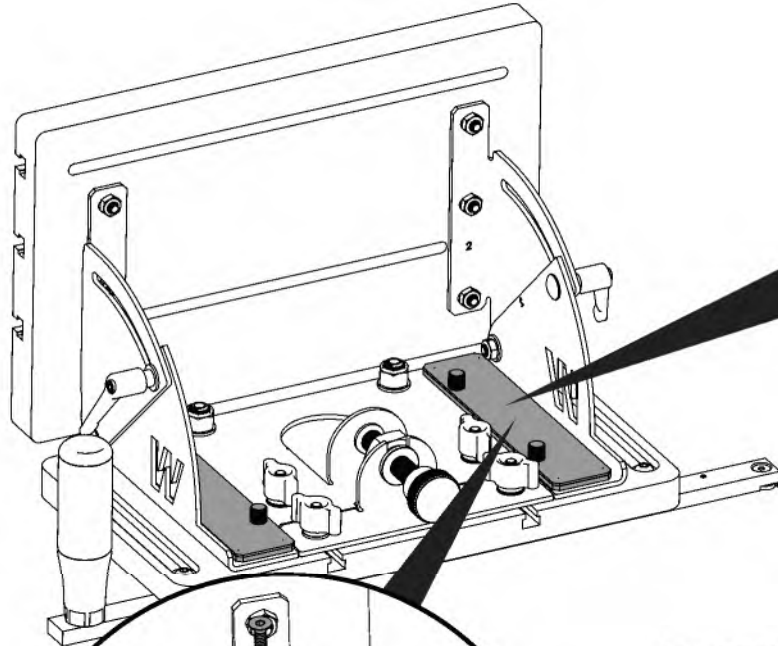

**1** Remove the left and right Bearing Covers

**3** Re-install the Bearing Covers

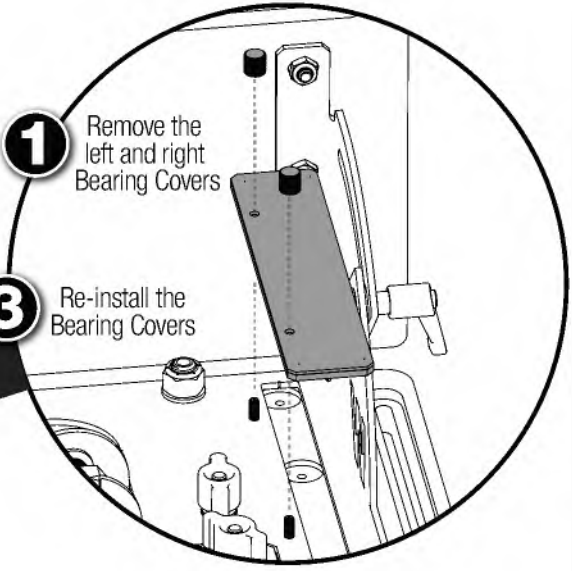

## Adjusting the Joinery Sled

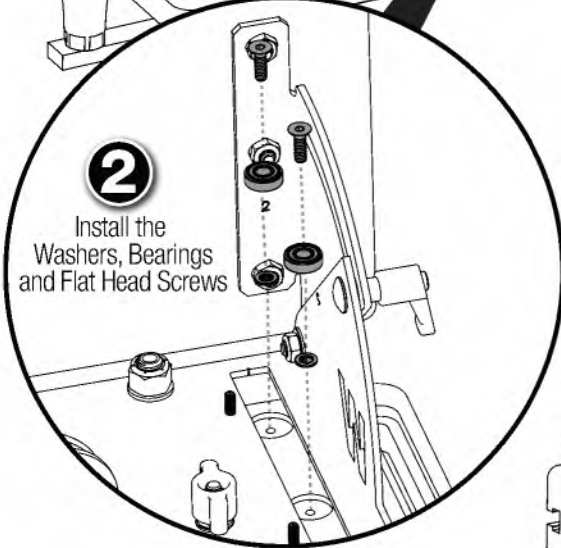

**2** Install the Washers, Bearings and Flat Head Screws

### Anti-Tipping Leveling Feet

Adjust the Leveling Feet inside the Base Nuts until they are just touching the table.

**5**  $\frac{3}{16}$ "

### Angle Adjustment

Adjust the angle of the Clamping Table. Pull the Knob outward and spin for ease of positioning.

**4**

No T-Slot? Remove the Oval Nut

$\frac{1}{8}$ "

### Fence Adjustment

Adjust the angle and position of the Fence by loosening the (2) Fence Thumbturn Knobs. A (2) Set Screw inside the lower knob lets you adjust vertical position.

$\frac{1}{8}$ "

**6**

**1** Loosen the (2) Pan Head Screws to align the Clamping Table (See Calibration in Part I).

$\frac{5}{32}$ "

Sliding Sled Base Adjustment

**2** Loosen all (4) black and red Thumbturn Knobs. Move the Sliding Base by hand and re-tighten all four Knobs.

Quick Adjustment

**3** Loosen only the red Thumbturn Knobs. Spin the Micro-Adjuster to dial in a precise setting.

Micro-Adjustment

## I. ASSEMBLY

### 1. INSTALL THE GUIDE BEARINGS

- A. This process is easiest with the Joinery Sled set in your miter slot. Set the Clamping Table vertical by loosening the Angle Adjustment Knobs. Crack loose the (2) black and (2) red Thumbturn Knobss so the table assembly can move.
  - B. Remove the (4) Stainless Steel Knobs and slide off the (2) Bearing Covers. **FIGURE A.**
  - C. Place the Washers and Bearings over the tapped holes in the Sliding Sled Base Plate. Guide each 10-24 x 5/8" Screws through the Bearing/Washer, into the tapped holes. Thread the Screws in a turn or two, just enough to keep the Screw in place. **FIGURE B.**
- STOP** The Bearings must be fully seated inside the track cut-out. Wiggle the Sliding Sled Base to ensure the Bearings ride along the track cut-out.
- D. Tighten all (4) Screws finger-snug only at this point.
  - E. Using the 1/8" Hex Key, tighten all (4) Screws just a little past finger-snug. As you tighten each Screw, the Bearings are drawn in towards the center. This allows the Sliding Sled Base to slide straight and allows you to control the level of tension.
  - F. As you progressively tighten all (4) Screws, about a quarter-turn at a time, slide the Sliding Sled Base back and forth to feel that it slides smooth and straight without binding.
  - G. When the Sliding Sled Base moves smoothly without excessive side-to-side play, re-install the Bearing Covers. **FIGURE A.**

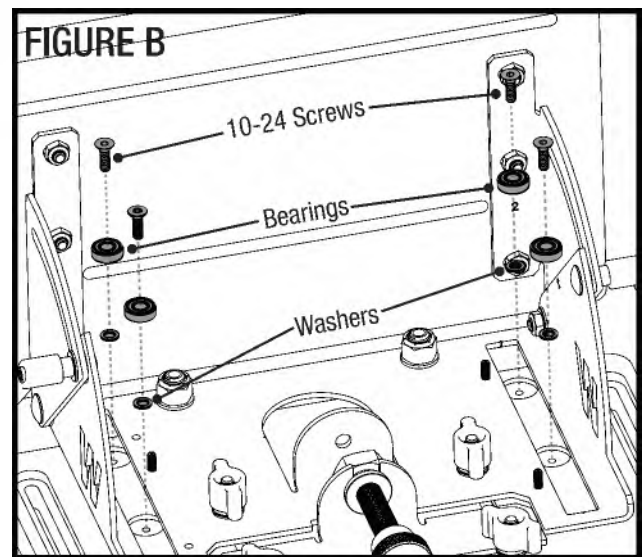
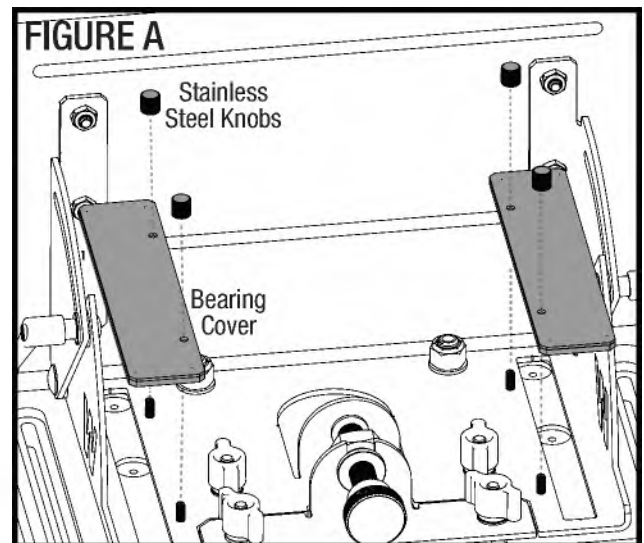

### 2. ASSEMBLE & INSTALL THE FENCE

- A. Thread the (2) Set Screw into the (1) Weld Nut so the end of the Set Screw is flush with the Weld Nut. The socket head side should be facing away from the Weld Nut. **FIGURE C.**
- B. Guide the (1) Weld Nut and the (3) Hex Head Bolt into the T-track opposite the engraved logo of the Fence, and guide the stems of the (2) Set Screws into the slots in the front of the Clamping Table.
- C. From the back of the Clamping Table, install a Red Knob and (3) Stainless Steel Washer on both stems of the (2) Set Screw assemblies.
- D. Assemble the Sacrificial Fence by guiding (3) (4) Button Head Screws through the counterbored slots and loosely threading (1) Weld Nuts onto the (4) Button Head Screws.
- E. Guide the (1) Weld Nuts into the front T-Track on the Fence. When the Fence is at the desired location, tighten the (4) Button Head Screws using the 5/32" Hex Key.

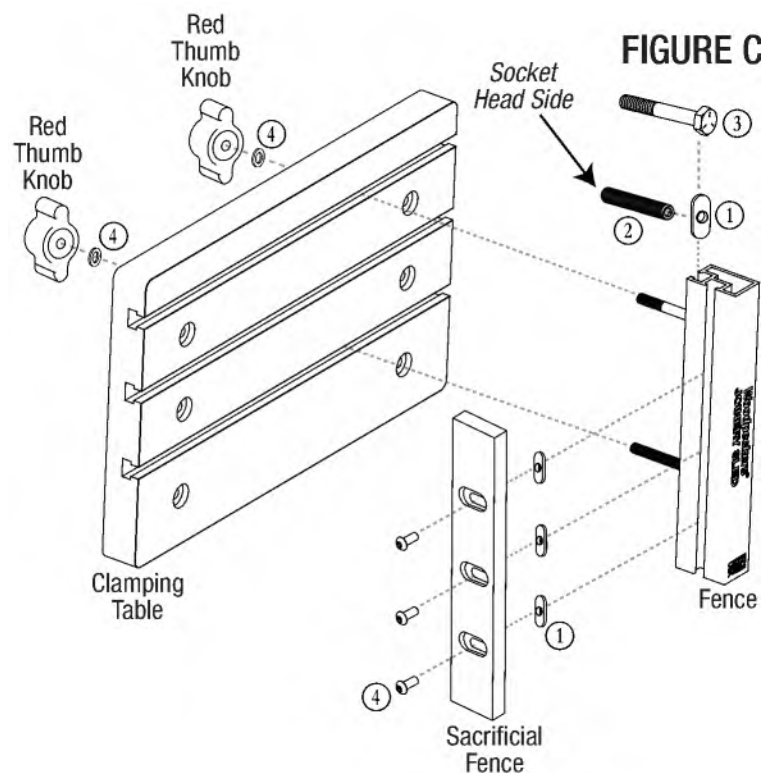

**NOTE:** Refer to Section II, Step 3.F on page 5 to set your Fence to a minimum height.

## II. CALIBRATION & ADJUSTMENT

### 1. SET THE LEVELING FEET

- With the Joinery Sled set in your miter slot, set the Clamping Table vertical by loosening the Angle Adjustment Lock Knobs.
- Place the 3/16" Hex Key inside the hollow Screw/Nut at the base of the Clamping Table. **FIGURE D.**
- From the front of the Clamping Table, look underneath the Screw/Nut to see the Set Screw inside. Turn the Set Screw until the Set Screw is just touching the Clamping Table (*avoid the blade insert*). The Leveling Feet should support the Clamping Table when extended but should not lift the base off the Clamping Table.

**NOTE** Make sure the Leveling Feet are set to the Clamping Table itself, not the Blade Insert.

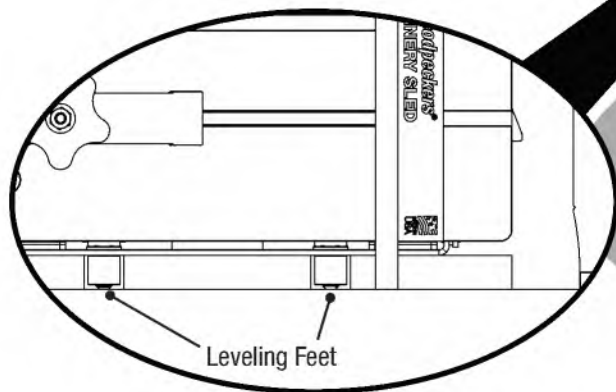

### PRO TIP

Place a piece of paper underneath the Sliding Sled Base when setting the Leveling Feet. By pulling on the paper while adjusting, you can feel when the Leveling Feet are supporting the Clamping Table.

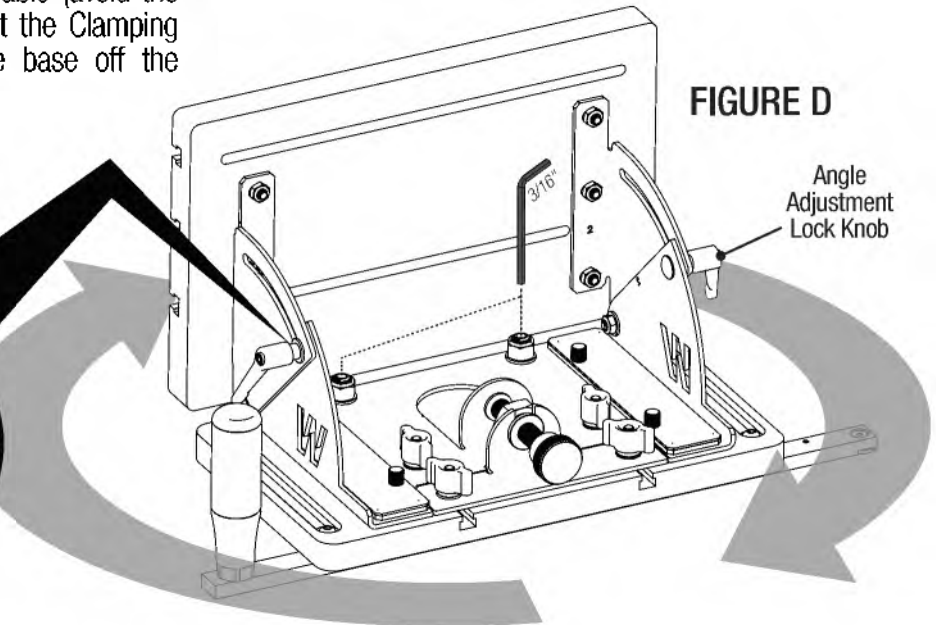

### 2. SET THE TABLE PARALLEL TO THE CUTTER

- With the Joinery Sled set in your miter slot, set the Clamping Table vertical by loosening the Angle Adjustment Lock Knobs. Locate the sled next to the cutter (*router bit or saw blade*).
- Loosen the Sled Base Adjustment screws using a 5/32" Hex Key.
- Place a Setup Block (*Sold separately*) or your prepared workpiece (*something known to have parallel faces*) between the Clamping Table and the cutter. **FIGURE E.** Use the setup block to set an equal distance between the cutter and Clamping Table at the leading edge and trailing edge of the Clamping Table. Tighten the Sled Base Adjustment Screws enough to keep it from moving. Double check the front and back and adjust as necessary.
- Firmly tighten the Sled Base Adjustment Screws. The Clamping Table now moves in the miter slot parallel to the blade (*or tangentially to the front of the router bit*).

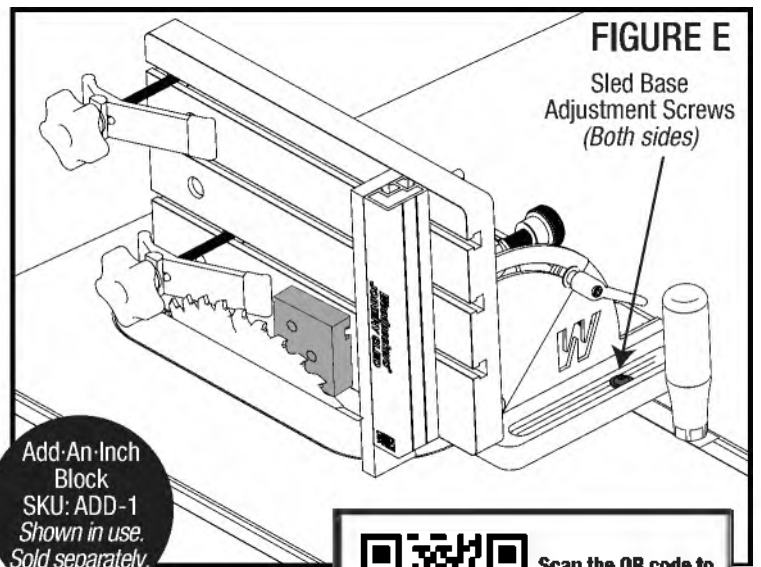

Scan the QR code to watch the video on calibrating the Joinery Sled on Woodpeckers Deep Dive!



### PRO TIP

Substitute your router bit with a solid rod or steel dowel for easier calibration at the router table.

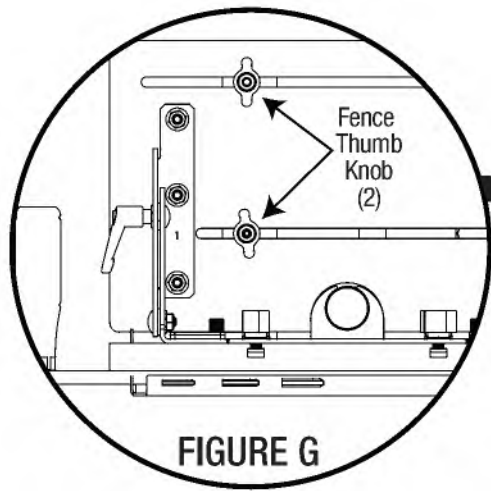
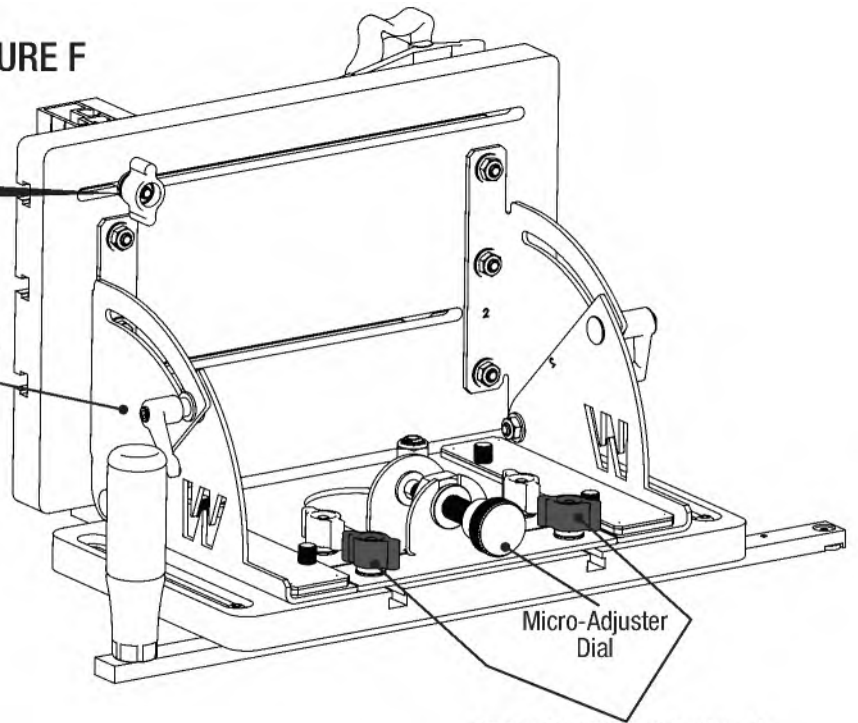

FIGURE F

Angle Adjustment Plate (2)  
w/ Angle Adjustment Lock Knob (2)



Sliding Sled Base Adjustment  
Thumbturn Knob (Red) (2)

Micro-Adjust Base Thumbturn Knobs (Black) (2)

**NOTE** For best results, calibration of the Table should be done by referencing the workpiece clamped to the Table.

### 3. CLAMPING TABLE ADJUSTMENT

- A. Quick adjustment allows for a maximum 3-1/2" of movement. Within that travel, the micro-adjustment allows for a maximum 1" of movement. **FIGURE F.**
- B. Loosen all (4) Sliding Sled Base Adjustment (red) and Micro-Adjust Base Thumbturn Knobs (black) to quickly adjust the Sliding Sled Base.
- C. With the Micro-Adjust Base Thumbturn Knobs (black) tight and the Sliding Sled Base Adjustment Thumbturn Knobs (red) loose, spin the Micro-Adjuster Dial clockwise to move the Clamping Table closer to the cutter and counter-clockwise moves the Clamping Table away from the cutter. **NOTE:** The gap between the Micro-Adjust Base and the Sliding Sled Base does not need to be parallel. The linear bearings ensure the Sliding Sled Base remains true.
- D. Adjust the angle of the Clamping Table by loosening the (2) ratcheting Angle Adjustment Lock Knobs. Use a bevel gauge, square, or your mating workpiece to set the angle to the Clamping Table.
- E. Adjust the angle and position of the Fence by loosening the (2) Fence Thumbturn Knobs on the back of the clamping table. Use a bevel gauge, square, or your mating workpiece to set the desired angle.
- F. The height of the Fence can be set to a minimum height to prevent accidental contact with the cutter. To adjust the vertical position of the Fence, crack loose the set screw inside the lower Fence Thumb Knob using a 1/8" Hex Key. While holding the Fence, loosen the (2) Fence Thumbturn Knob. Set the height and re-tighten the Set Screw and Fence Thumbturn Knob. **FIGURE G.**
- G. The Sacrificial Fence can be positioned along the Fence with (2) or (3) Screws, as needed for the cut at-hand. Crack loose the Screws using a 5/32" Hex Key, position the Fence, then tighten the Screws. Always use a minimum of (2) Screws.
- H. The included Hold-Down Pivot Clamps work with either arm securing the workpiece. Always ensure the pivoting dowel is fully seated in the mating recess of the clamp arm. Over-tightening the Hold-Down Pivot Clamps or tightening the Clamp while improperly seated may damage the Clamping Table and/or Hold-Down Pivot Clamps.

#### **IV. INSTALLING THE RACK-IT®**

- A. Find a suitable location to mount the Rack-It. The weight of the Joinery Sled requires a stud, plywood, or other sturdy backing in order to mount the Rack-It.
- B. We've included two lag bolts and washers for mounting the Rack-It. Mark the first hole on the wall and drill the first pilot hole using a 3/32" bit.
- C. Place the Rack-It on the wall and align one of the center holes with your drilled pilot hole. Drive the first lag bolt/washer, leaving the lag bolt slightly loose.
- D. Make sure the Rack-It is level and mark the second hole location. Drill the second 3/32" pilot hole and then drive the second lag bolt/washer and finish driving the first lag bolt.
- E. We drilled additional holes if you prefer mounting in a different method. The slotted holes are located to fit both 10" and 250mm spacing. We recommend (4) #10 or #12 screws into sturdy backing like plywood or sheet metal panel.

## V. GETTING TO KNOW YOUR NEW JOINERY SLED

- A. The Joinery Sled can tackle many different complex joints like castle joints, tenons, bridle joints, half laps, sliding dovetails, and more. A half lap or bridle joint is a good example of a joint to make with the Joinery Sled to become acclimated with your new tool. Both of these joints are featured on our Deep Dive for the Joinery Sled.
- B. Mill three lengths of stock (roughly 3/4" thick and 1-1/2" wide, about 8"-10" in length). Lay out your joint according to **FIGURE H**.
- C. Set the blade height and make sure your Joinery Sled is calibrated square to the table and cutter.
- D. Start with the bridle cut. Clamp the workpiece to the table and align the blade to your layout mark using the micro-adjust. Flip the workpiece on the Clamping Table to ensure that your joint is perfectly centered and make a second cut.
- E. Before you remove the workpiece, align the blade to the bridle wall. This will be the cheek for the tenon workpiece. Set it just slightly too far towards the waste side and you can micro-adjust to the perfect fit.

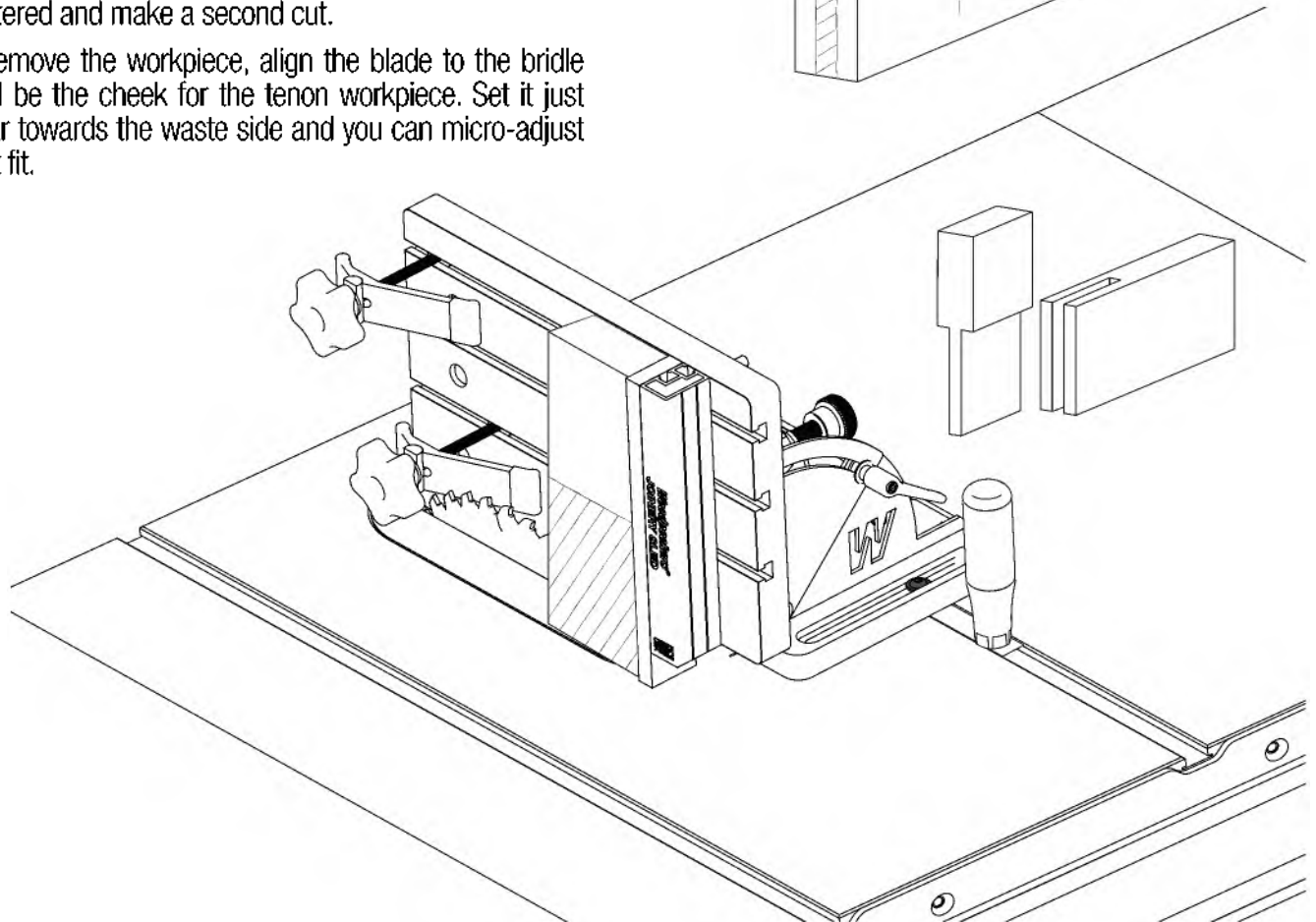
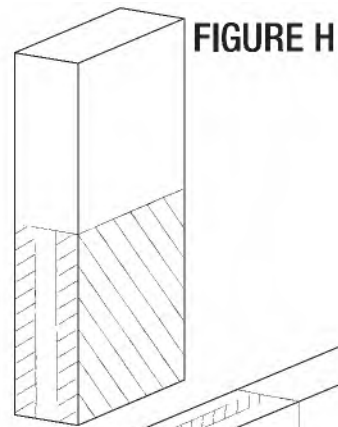

- F. Clamp the tenon workpiece to the table. Make the first cut, flip the workpiece on the clamping table and make the second cut.
- G. Test the fit of the two pieces. Use the micro-adjust to dial in on the perfect fit.
- H. If you're a visual learner, watch our Deep Dive on the Joinery Sled by scanning the QR code below!



Scan the QR code to watch the video on calibrating the Joinery Sled on Woodpeckers Deep Dive!



**Woodpeckers®**  
woodpeck.com

**OTHER PRODUCTS WE THINK YOU'LL LOVE...**

DESCRIPTION	SKU
Semble® Screw-Type Track Clamps (4-pk)	G20KP-4
Ultra-Shear® 10" Flat Top Grooving Blade	USFTGSET-3PC
Woodpeckers® Variable Helix Joinery Router Bit	USUV-12PC
Woodpeckers® Sliding Bevel Gauge & Bevel Block	SBG-DEL-23
Woodpeckers® Additional Sacrificial Fences	JSLED-SF
Woodpeckers® Add-An-Inch Block	ADD-1



**WARNING!** To reduce the risk of injury keep hands away from sharp blades.



**WARNING!** To reduce the risk of injury, wear safety goggles or glasses with side shields, ear protection & a dust mask.

**Woodpeckers®**

Woodpeckers, LLC Strongsville, Ohio  
**woodpeck.com**  
© 2025 Woodpeckers, LLC



**At Woodpeckers we are constantly reviewing & improving our tools. The most current version of our instruction manuals are always available to download at woodpeck.com.**  
*(Located in the bottom section of the tool's page under the "Additional Information" or "Instructions" tabs.)*



**Be the first to know all the new products, OneTIME Tools & sales by subscribing to our eClub.** *(Located at the top center of our webpage woodpeck.com.)*



**Subscribe to our YouTube channel to stay up-to-date on all the latest tool tips & tricks.**



**INTERACT WITH US! Follow us on Facebook, Instagram & TikTok!**



**Enjoy shop tips, project ideas, tool techniques & more in our Woodworking Resource Center/Blog.** *(Located at the bottom center of our webpage woodpeck.com.)*



**WARNING!**

This product can expose you to chemicals, including chromium, which is known to the State of California to cause cancer and birth defects or other reproductive harm. For more information go to [www.P65Warnings.ca.gov](http://www.P65Warnings.ca.gov)