

Woodpeckers®

AUTO SCALE™

MITER SLED DROP ZONE

OWNER'S MANUAL

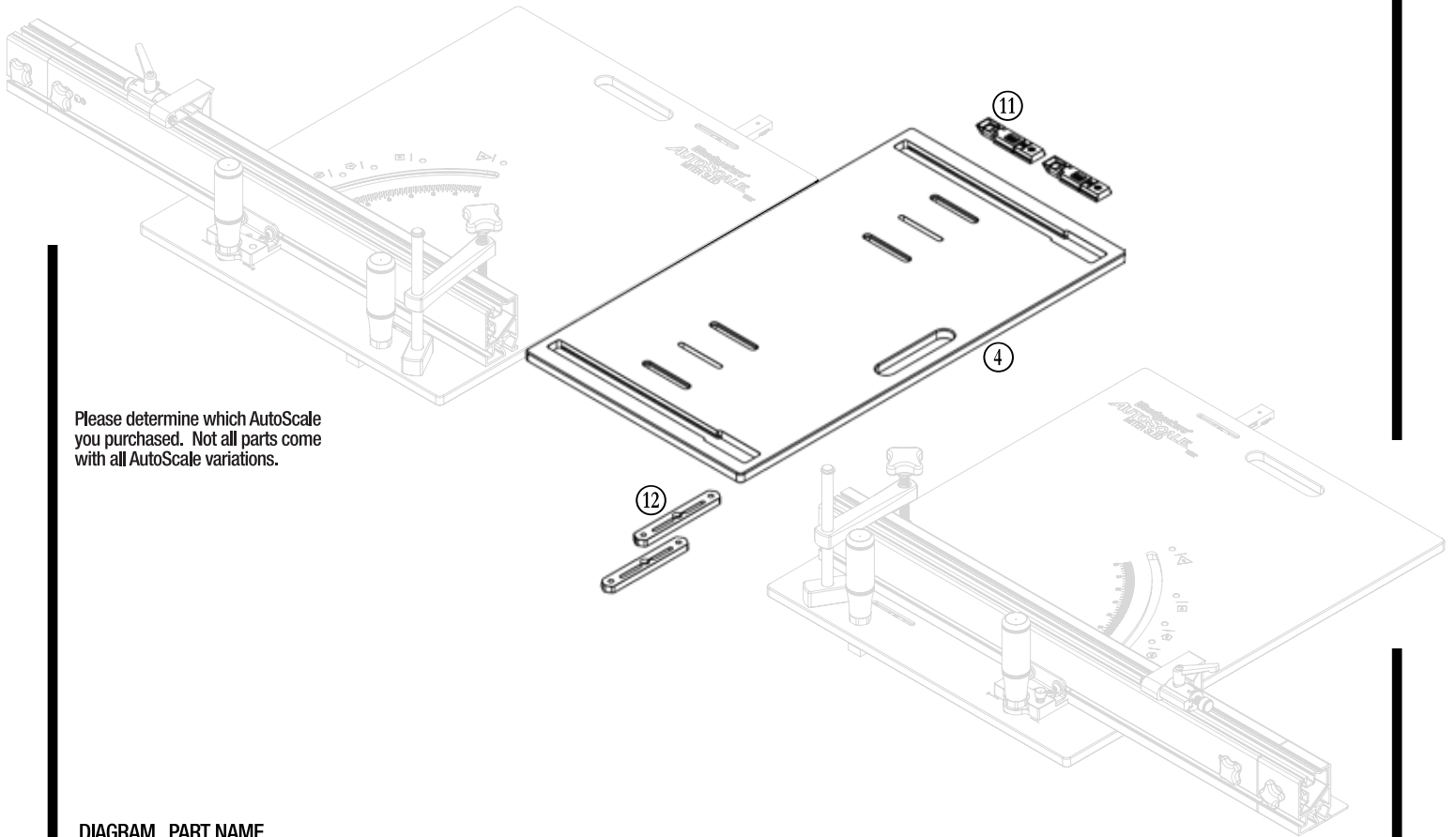

Please determine which AutoScale you purchased. Not all parts come with all AutoScale variations.

DIAGRAM NUMBER	PART NAME	Qty
④	Drop Zone Base	(1)
--	Hex Key, 1/8"	(1)
HARDWARE BAG G		
⑪	Stealth Stop	(2)
⑫	Clamping Miter Bar	(2)
--	Button Head Cap Screw #10-32x3/4"	(4)
--	Flat Head Cap Screw #10-32x3/8"	(2)
--	Nut #10-32	(4)
--	Oval Nut #10-32	(2)



Scan the QR code above to watch the video or visit woodpeck.com under the video tab towards the bottom of the product page.

If you think you're missing anything, email us at mailroom@woodpeck.com.
You can also call us at 800-752-0725 from 9:00 a.m. to 4:00 p.m. EST Monday - Friday.

- L** Refers to the instructions for assembling the Left side.
- R** Refers to the instructions for assembling the Right side.

I. STEALTH STOPS

AT THIS POINT YOU WILL NEED:

- Hex Key, 1/8"
- **HARDWARE BAG G**
- ⑪ Stealth Stop
- The StealthStop ⑪ is tool-free for raising/lowering the flag, and for micro-adjusting position. It does require the 1/8" Hex Key to lock the stop in place. When lowered, the StealthStop is fully below the surface of the track and out of the way. **FIGURES 1 & 1-A.**

FIGURE 1

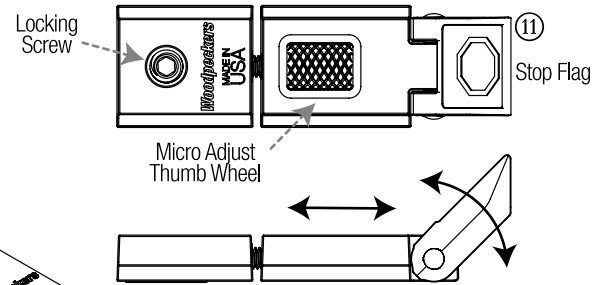

FIGURE 1-A

II. CLAMPING MITER BAR & DROP ZONE ASSEMBLY

AT THIS POINT YOU WILL NEED:

- ④ Drop Zone Base
- Hex Key, 1/8"
- **HARDWARE BAG G**
- ⑫ Clamping Miter Bar
- Button Head Cap Screw #10-32x3/4"
- Flat Head Cap Screw #10-32x3/8"
- Nut #10-32
- Oval Nut #10-32

YOU WILL ALSO NEED: Combination Square (Not included)

1. Insert a Flat Head Cap Screw through the center countersunk hole in the Clamping Miter Bar ⑫. Loosely thread an Oval Nut onto the Flat Head Cap Screw using an 1/8" Hex Key. Repeat for the second Clamping Miter Bar. *This Flat Head Cap Screw will be tightened in later steps to expand the Clamping Miter Bar to create a tight fit in the miter slot.* **FIGURE 2.**
2. Install (2) Nuts into the hexagon countersunk hole on each Clamping Miter Bar. This can be easily done by threading the nut onto the end of a Button Head Cap Screw, and then press them into place by hand. Once installed, remove the Button Head Cap Screw.
3. Orient the Clamping Miter Bar on the bottom of the AutoScale Miter Sled as shown. The thinner edge of the Clamping Miter Bar should be facing the handle side of the Drop Zone ④. **FIGURE 3.**
4. Secure the Clamping Miter Bar to the Drop Zone by inserting (2) Button Head Cap Screws through the countersunk/elongated slots in the top of the Drop Zone. Thread the Flat Head Cap Screws into the (2) Nuts in the Clamping Miter Bar. Loosely secure them at this time, you should still be able to slide them left and right. **FIGURE 2.**
5. **L** Take a measurement from the right side of your table saw blade to the inside wall of your right miter slot and subtract 1/16".
5. **R** Take a measurement from the left side of your table saw blade to the inside wall of your left miter slot and subtract 1/16".
6. Use a combination square and set it to match the measurement you just took.
7. Using the combination square, set the Clamping Miter Bars to be parallel with the edge of the Drop Zone that does not have the hand cut-out, and tighten the (2) Button Head Cap Screws with an 1/8" Hex Key to secure the Clamping-Miter Bars in place.

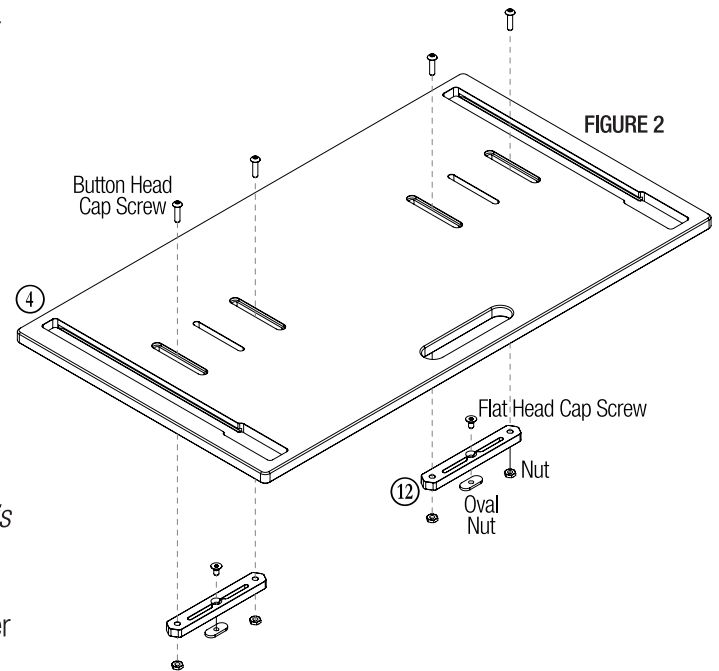
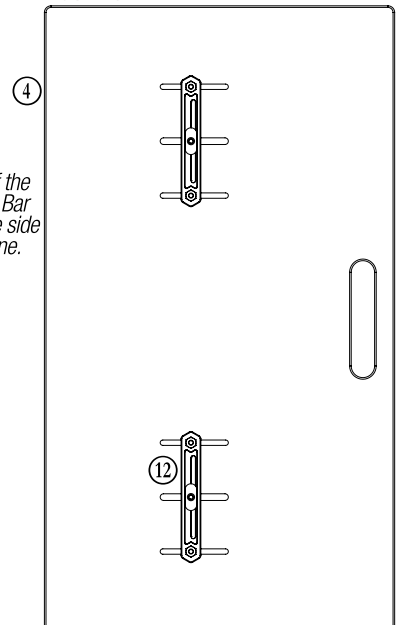

FIGURE 2

FIGURE 3



8. **L** Install the Drop Zone into the right miter slot of your table saw. Verify that the Drop Zone does not come in contact with the blade. If it does, make any necessary adjustment by repeating the previous steps. The edge of the Drop Zone should be parallel, and 1/16" away from your table saw blade.

8. **R** Install the Drop Zone into the left miter slot of your table saw. Verify that the Drop Zone does not come in contact with the blade. If it does, make any necessary adjustment by repeating the previous steps. The edge of the Drop Zone should be parallel, and 1/16" away from your table saw blade.

9. Increase the clamping pressure of the Miter Clamping Bars with the Drop Zone installed, by tightening the (2) Flat Head Cap Screws with an 1/8" Hex Key. Do not over-tighten the Flat Head Cap Screws.

NOTE: To test the fit, slide the Drop Zone forward and backward checking to see that it still moves, but has adequate resistance. There should be enough resistance that the Drop Zone remains in place while using it to support the off-cut of your workpiece. Lastly, test to see that you can remove and re-install the Drop Zone in your table saw t-slot. While installed there should be no left-to-right play.

III. DROP ZONE CALIBRATION

1. Begin by installing a StealthStop **11** in the Drop Zone **4**. Use a square to assist in setting the Stealth Stop at the 1" mark. When you get it in place, lock it down with the 1/8" Hex Key. **FIGURE 4.**

2. Using the Flip Stop Flag from the AutoScale Miter Sled as a 1" gauge block. Place it between the Stealth Stop and your table saw blade. Ensure that it fits snug. If left-to-right adjustment is needed to dial in the scale, simply loosen the Button Head Screws on the Miter Clamping Bars to adjust the Drop Zone, and then re-tighten the Button Head Screws.

IV. USING THE STEALTHSTOP

- To lock/unlock the StealthStop, use the Hex Key in the exposed hex of the locking screw.
- To move the StealthStop around quickly, use the Hex Key to loosen the lock, and then move the stop with the Hex Key still installed.
- To micro-adjust the position of the StealthStop, spin the knurled brass thumb wheel to move the flag forward or backward.
- To raise / lower the Stop Flag, simply use your finger tip to snap it up or down.
- To set the StealthStop to a specific dimension, flip up the Stop Flag and push the workpiece against the stop, read the scale where it intersects the workpiece. If the workpiece does not intersect the scale, use a small square (such as the Woodpeckers MiniSquare, Not Included) to read the scale.

FIGURE 4

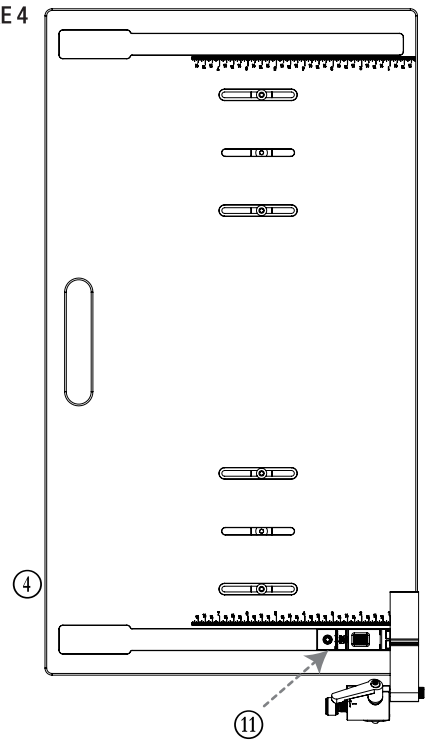

Woodpeckers®

Woodpeckers, LLC Strongsville, Ohio
woodpeck.com
© 2022 Woodpeckers, LLC



At Woodpeckers we are constantly reviewing & improving our tools. The most current version of our instruction manuals are always available to download at woodpeck.com.

(Located in the bottom section of the tool's page under the "Additional Information" or "Instructions" tabs.)



Be the first to know all the new products, OneTIME Tools & sales by subscribing to our eClub. *(Located at the top center of our webpage woodpeck.com.)*



Subscribe to our YouTube channel to stay up-to-date on all the latest tool tips & tricks.



INTERACT WITH US! Follow us on Facebook, Instagram & TikTok!



Enjoy shop tips, project ideas, tool techniques & more in our Woodworking Resource Center/Blog. *(Located at the bottom center of our webpage woodpeck.com.)*



WARNING! To reduce the risk of injury keep hands away from moving parts. Refer to your power tool manual for proper setup and use.



WARNING! To reduce the risk of injury, wear safety goggles or glasses with side shields, ear protection & a dust mask.



WARNING! This product can expose you to chemicals, including chromium, which is known to the State of California to cause cancer and birth defects or other reproductive harm. For more information go to www.P65Warnings.ca.gov