

Woodpeckers®

DELUXE CUTTING BOARD KIT

OWNER'S MANUAL

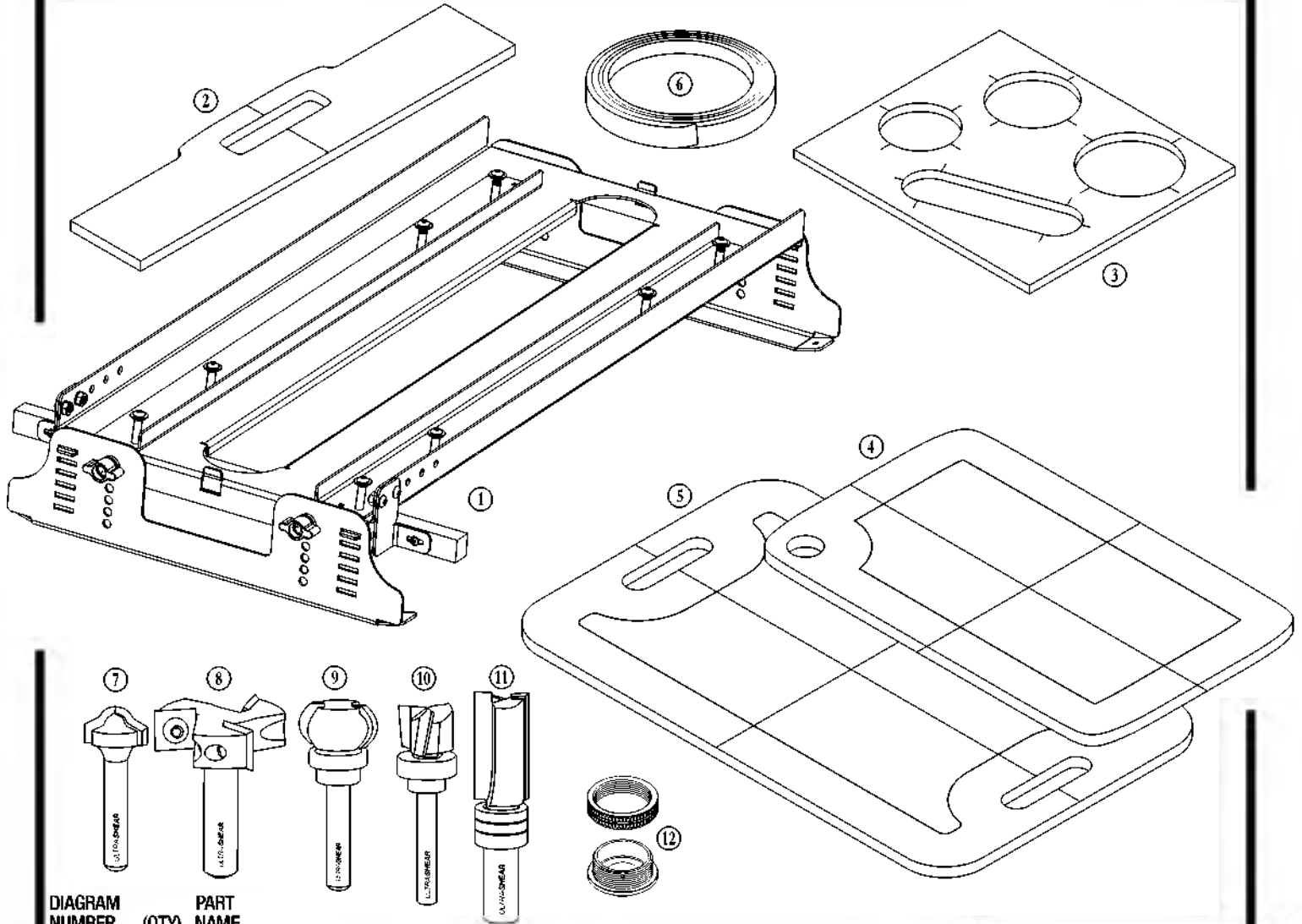

DIAGRAM NUMBER

(QTY) PART NAME

- ① (1) Rout-N-Plane Bench Top Board Mill XL
- ② (1) Cutting Board Handle Template, Outside dimensions 15-7/8" x 3-3/4"
- ③ (1) Cutting Board Ramekin/Bowl Template, Overall dimensions 11.875" x 10.5"
- ④ (1) Small Cutting Board Template with Juice Groove, 2-Piece, 13" x 18"
- ⑤ (1) Large Cutting Board Template with Juice Groove, 2-Piece, 10.75" x 17.75"
- ⑥ (1) SpecTape® Double-Sided Adhesive Tape, 1" x 36 yards
- ⑦ (1) Ultra-Shear® Carbide-Tipped Juice Groove Router Bit, 1/4" Shank, 3/8" Round Nose (US2375JG2F)
- ⑧ (1) Ultra-Shear® Carbide Insert Slab Flattening Spoilboard Bit 1/2" Shank, 1-1/2" Dia. (US515SF)
- ⑨ (1) Ultra-Shear® Carbide-Tipped Finger Grip Groove Router Bit, 1/4" Shank, for 1" Boards (US210FGGR)
- ⑩ (1) Ultra-Shear® 3-Flute Compact Shallow Pattern Router Bit, 1/4" Shank, 5/16" Cut Length (US2188CSP)
- ⑪ (1) Ultra-Shear® Carbide-Tipped Template Pattern Router Bit, 1/2" Shank, 1-1/2" Cut Length (US57515TP)
- ⑫ (1) Ultra-Shear® Juice Groove Template Guide Bushing, 13/16" ID, 1" (OD USJGTGB)



Scan the QR code above to watch the video or visit woodpeck.com under the video tab towards the bottom of the product page.

If you think you're missing anything, email us at mailroom@woodpeck.com. You can also call us at 800-752-0725 from 9:00 a.m. to 4:00 p.m. EST Monday - Friday.

Thank you for purchasing the **Woodpeckers Cutting Board Kit**. This kit offers some easy ways to add thoughtful details to your cutting boards that will distinguish yours amongst the rest. The Templates and specially-designed bits make handles and juice grooves easy. And with the Rout-N-Plane® Bench Top Board Mill, now you can flatten your projects without needing a planer at all.

I. ASSEMBLY

- To assemble the Rout-N-Plane® Bench Top Board Mill, follow the instructions included with the tool.
- No other assembly is required, but you can immediately remove the protective film from the acrylic Templates.

II. ROUT-N-PLANE® BENCH TOP BOARD MILL

- The Rout-N-Plane Bench Top Board Mill allows you to flatten projects as thin as 3/4" all the way up to 3" thick. **Read the instructions included with the Board Mill for operation.**
- The tool is perfect for end-grain cutting boards that you should not run through your planer. Just surface one side, flip the workpiece over, and surface the other side. You can do the same thing with edge grain cutting boards or large panels that are too big for the planer.
- Install the Carbide Insert Slab Flattening Spoilboard Bit ⑧ in your router to use with the Board Mill.

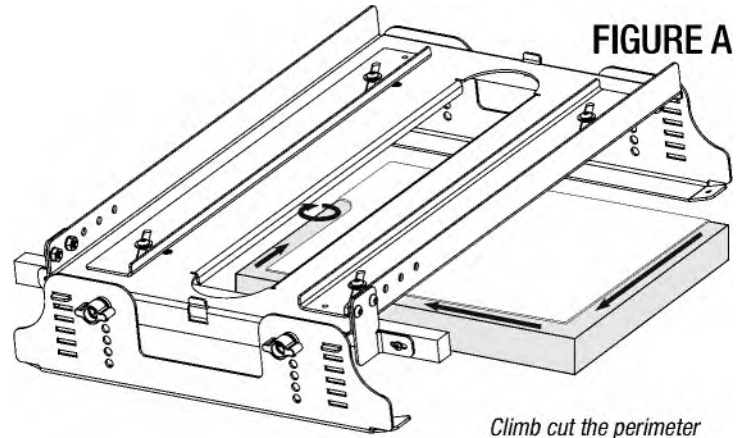

FIGURE A

Climb cut the perimeter first to minimize tear out

PRO TIP

To reduce tear out when surfacing, carefully perform a climb cut around the perimeter. **FIGURE A.**

III. CUTTING BOARD TEMPLATES w/ JUICE GROOVES ④ ⑤

1. PREPARING THE MATERIAL

- First, you need to remove the bulk of the waste before routing. Lay out the centerlines of the Template on your workpiece. Align the Template to the marks and trace the Template (including the handles) onto the workpiece. **FIGURE B.**
- For the handles, drill undersized holes to later rout the side walls at the router table. For the longer handle on the larger cutting board, drill two holes at either side of the handle and remove the bulk of the waste with a jig saw, or multiple holes at the drill press. **As with any routing operation where you are routing the inside of a hole, take care that no material is touching the bit when starting the router.**
- At the band saw or with a jig saw, carefully cut on the outside of your lines, leaving $\pm 1/8"$ of material outside the lines.
- Cut strips from the roll of the SpecTape, Double-Sided Adhesive Tape ⑥ and attach to the underside (with engraved centerlines) of the Template. Take care to avoid spanning the cut-out. **FIGURE C.**
- Remove the adhesive protection strip and stick the Template to your cutting board blank, aligning the engraved centerlines to your layout marks. **FIGURE B.**
- Apply firm pressure to the top of the Template for 10-15 seconds to activate the adhesive.

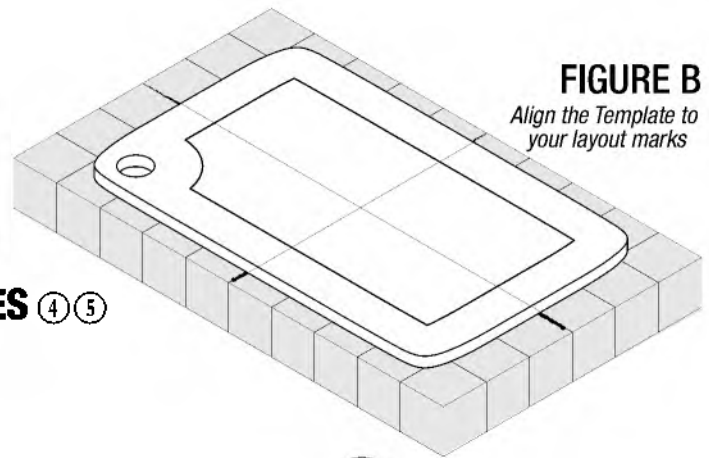

FIGURE B

Align the Template to your layout marks

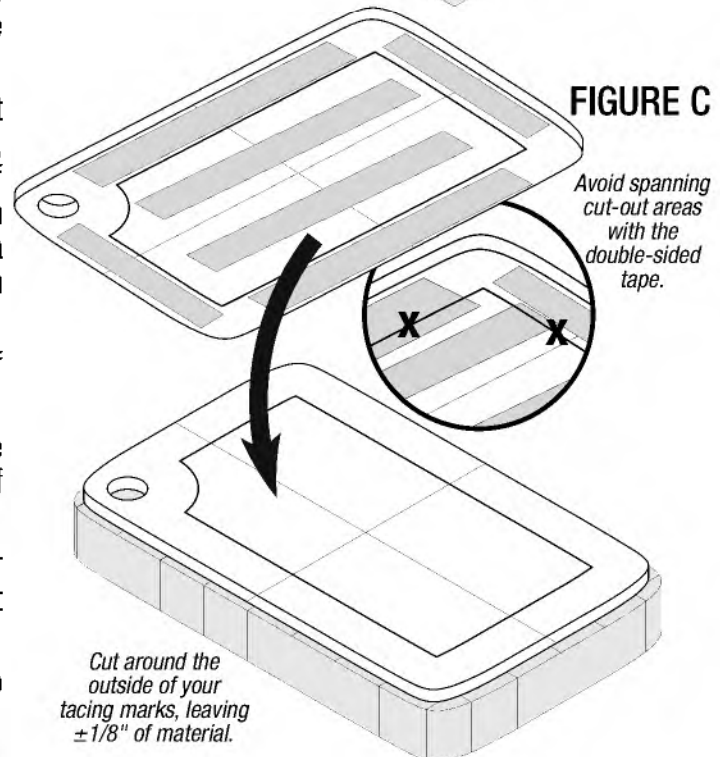

FIGURE C

Avoid spanning cut-out areas with the double-sided tape.

Cut around the outside of your tacing marks, leaving $\pm 1/8"$ of material.

2A. USING THE TEMPLATE WITH A ROUTER TABLE

- A. Install the Carbide-Tipped Template Pattern Router Bit ⑪ in your router table.
- B. With the Template face-down on the table, set the height of the bit so that the top bearing on the Template Pattern Bit aligns with the Template. **FIGURE D.**
- C. Use a starter pin to provide stability as you slowly enter the cut. **FIGURE D-1.**
- D. Feed the cutting board through the Template Pattern Bit while referencing the bearing. If your board comes off the bearing, re-engage the bearing behind the cut where the board is flush to the Template.

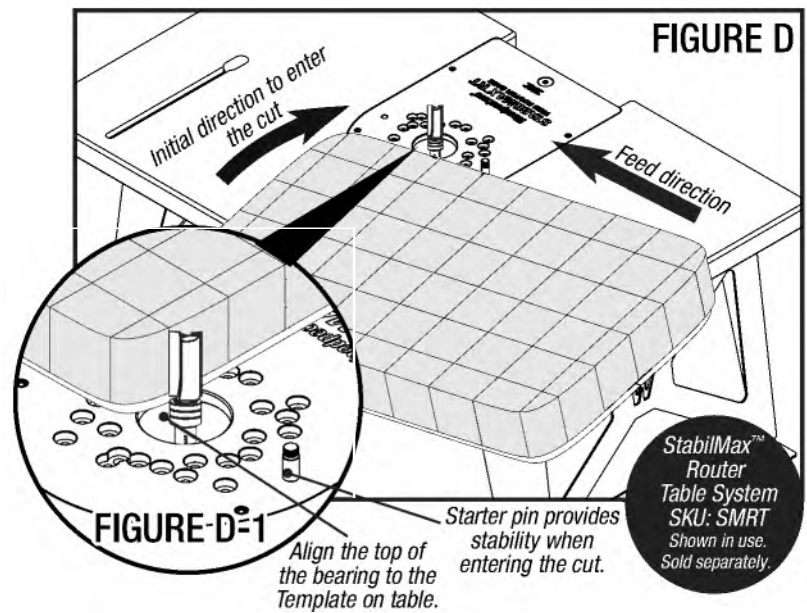

2B. USING THE TEMPLATE WITH A HANDHELD ROUTER

- A. Install the Carbide-Tipped Template Pattern Router Bit ⑪ in your handheld router.
- B. Secure the workpiece on a table with the Template facing up. You will need to use a sacrificial board underneath the workpiece to achieve a full-depth cut. **FIGURE E.**
- C. Place your router on the table and set the depth of cut so the bearing is aligned with the Template.
- D. Slowly enter the cut and guide the router along the Template in a counter-clockwise direction.

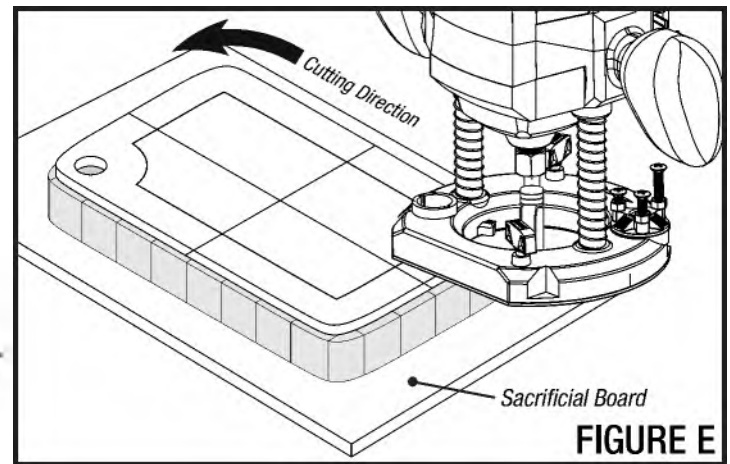

3. ROUTING THE JUICE GROOVE

- A. Remove the outer portion of the Template and leave the inner portion in place. **FIGURE F.** A painters tool or putty knife can help, but take care to not damage the workpiece.
- B. Install the Carbide-Tipped Juice Groove Router Bit (7) in your router and install the Juice Groove Template Guide Bushing (12) in the router's base.
- C. Set the depth of cut about 1/16" below the surface of the cutting board. You can do this by placing a spacer on top of the Template and lowering the bit to the surface.
- D. **If you're using a plunge router,** plunge into the cut and follow the Template in a counter-clockwise direction. **If you're using a fixed-base router,** you'll need to carefully tip the bit into the cut while referencing the Template. **FIGURE G.**
- E. Guide the router around the Template. Continue adjusting the depth of cut down about 1/16" at a time while routing around the Template until you've reached your desired depth.
- F. Remove the Template from the workpiece.
- G. To rout a juice groove on the opposite face, re-assemble the Template, align, and re-apply the Template to the other side.

FIGURE F

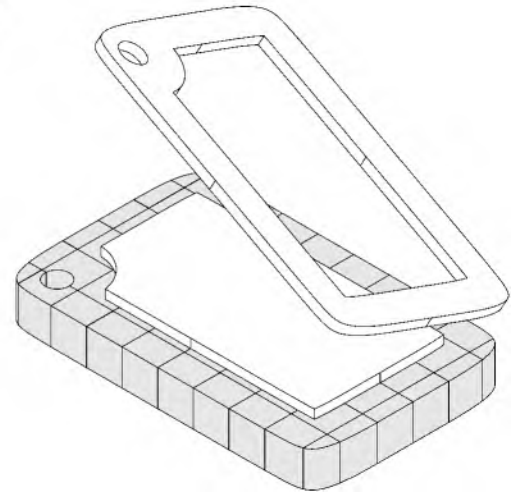
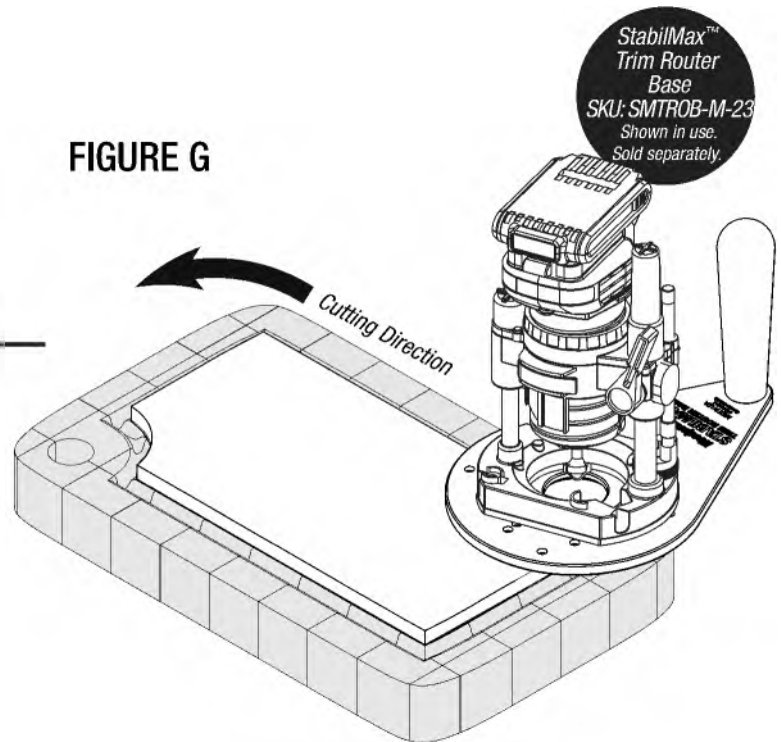

FIGURE G



4. ROUTING THE FINGER GROOVE HANDLES

- A. Install the Carbide-Tipped Finger Grip Groove Router Bit ⑨ in your router table or handheld router.
- B. Set the depth of cut so that the Finger Grip Groove Bit is centered on the thickness of the cutting board.
- C. You can rout the handles as long as you'd like or use stops to limit the length. **FIGURE H.**
- D. Rout the handles by guiding the workpiece or router while referencing the bearing to your desired length.

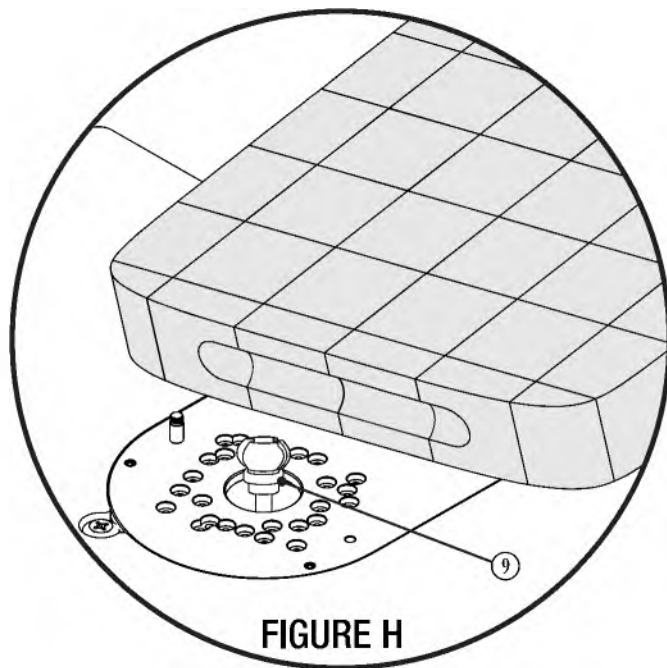

FIGURE H

IV. HANDLE TEMPLATE ②

The Handle Template is sized to accommodate most standard size cutting boards and allows you to rout a handle centered on nearly any project.

- A. Similar to the Cutting Board Template (Part III-1, Page2) trace the Handle Template onto the workpiece and remove the bulk of the waste.
- B. Cut strips from the roll of SpecTape, Double-Sided Adhesive Tape ⑥ and attach to the underside (with engraved centerlines) of the Template.
- C. Remove the adhesive protection strip and stick the Template to your cutting board blank, aligning the engraved centerlines to your layout marks. **FIGURE I.**
- D. Apply firm pressure to the top of the Template for 10-15 seconds to activate the adhesive.
- E. Install the Carbide-Tipped Template Pattern Router Bit ⑪ in your router or router table and set the depth of cut so the bearing is aligned with the Template.
- F. Rout the handle by guiding the router or workpiece along the bearing.

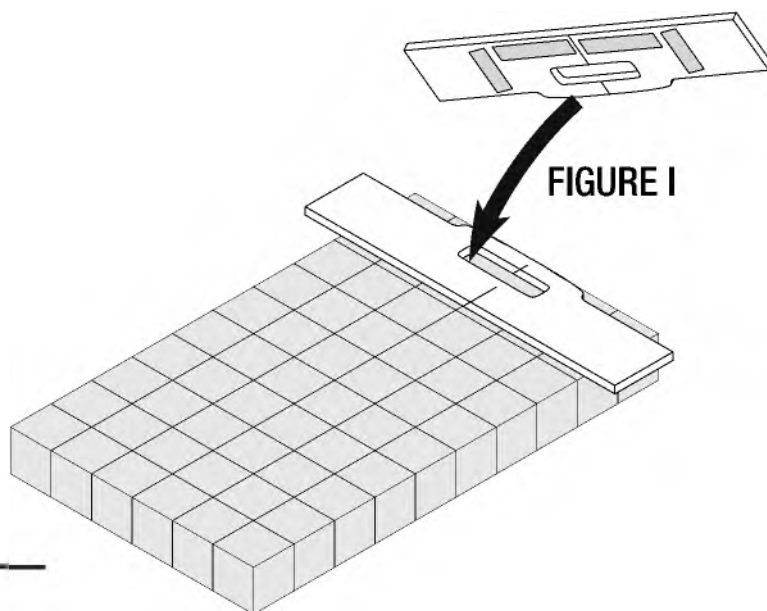
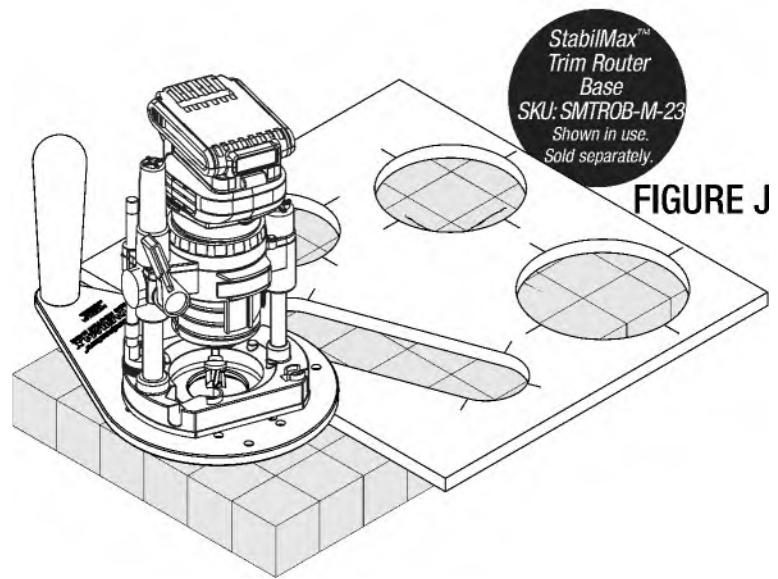

FIGURE I

V. RAMEKIN/BOWL TEMPLATE ③

The Ramekin/Bowl Template is sized to accommodate standard size ramekins and also gives you a Template for routing trays for crackers.

- A. Break off strips from the roll of SpecTape, Double-Sided Adhesive Tape ⑥ and attach to the underside (with engraved centerlines) of the Ramekin/Bowl Template.
- B. Remove the adhesive protection strip and stick the Template to your cutting board blank, aligning the engraved centerlines to your layout marks.
- C. Install the 3-Flute Compact Shallow Pattern Router Bit ⑩ in your router.
- D. Set your depth stop to the desired depth and set your initial depth of cut about 1/16" below the surface of the workpiece.
- E. Rout the entire area of the recess. Continue adjusting the depth of cut down about 1/16" at a time while routing around the entire recess until you've reached your desired depth.



PRO TIP

If you want to go even deeper, remove the Template and reference the bearing on the sidewall of the recess.



BONUS!

Here's an economical, simple recipe to make your own cutting board finish. Imagine including a small bottle of finish with each cutting board purchase or gift. It's a thoughtful touch that lets the recipient maintain their new favorite cutting board as the initial finish fades.

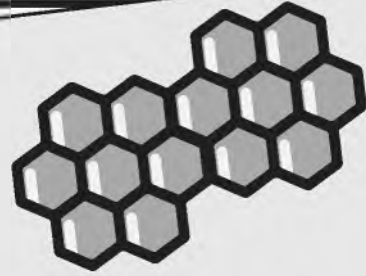

Cutting Board Wax Finish

Ingredients:

1/2 gallon of mineral oil (4 - 16oz bottles)
1lb bag of yellow beeswax pellets

Make It:

First cover your work surface with old plywood to protect your work surface.
Pour the mineral oil into the crock pot then add the beeswax.
Turn the crock pot to the highest setting.
Stir periodically.

The wax should fully melt in about 30 minutes.

Transfer the melted wax mixture into container(s). Shallow containers or tins with a lid work best.
Use caution this is very hot. It is useful to use a turkey baster or a measuring cup to transfer the mixture to avoid spilling.
Let it cool and solidify.

Use It: Apply a liberal amount of the Cutting Board Wax Finish to all surfaces of the board.
Allow it to sit 20-30 minutes. Use a clean cotton cloth to buff. Apply 1-2 coats and your board is ready to use. To revitalize used cutting boards, add a thin coat of the wax then buff after a few hours.

Store It: Store containers covered in a cool dry location.

NOTE: Do not wash cutting boards in the dishwasher. Hand wash only with soap & water.





Woodpeckers®

woodpeck.com

ADDITIONAL ACCESSORIES

While nearly any of our tools can help you make beautiful, top-quality cutting boards, here are a few additional accessories we think you'll love.

DESCRIPTION	SKU
• Wood Cutting Board Strip Kit	AMHWD-CB-KIT
• StabilMAX™ RT Router Table	SMRT
• StabilMAX™ Trim Router Base	SMTROB-M-23
• Handle Jig Plus	HJP
• Semble™ MD Parallel Jaw Clamps 4-Pack	PJM-SM-KIT
• Package 2 Premium Router Table Package	PRP-2-QL420SP
• SteadyCurve® Band Saw Template Guide	SC-22
• RackBit Router Bit Storage System	RB-27
• Ultra-Shear® 2-Flute, Carbide Tipped, Roundover Bit, 1/4" Shank - 4-Piece Set w/ Beading Bearing	USROSET-3
• Ultra-Shear® Flush Trim Bits	Various



WARNING! To reduce the risk of injury keep hands away from moving parts. Refer to your power tool manual for proper setup and use.



WARNING! To reduce the risk of injury, wear safety goggles or glasses with side shields, ear protection & a dust mask.

Woodpeckers®

Woodpeckers, LLC Strongsville, Ohio

woodpeck.com

© 2024 Woodpeckers, LLC



woodpeck.com

At Woodpeckers we are constantly reviewing & improving our tools. The most current version of our instruction manuals are always available to download at woodpeck.com. (Located in the bottom section of the tool's page under the "Additional Information" or "Instructions" tabs.)



Be the first to know all the new products, **OneTIME Tools & sales** by subscribing to our eClub. (Located at the top center of our webpage woodpeck.com.)



Subscribe to our YouTube channel to stay up-to-date on all the latest tool tips & tricks.



INTERACT WITH US! Follow us on Facebook, Instagram & TikTok!



Enjoy shop tips, project ideas, tool techniques & more in our Woodworking Resource Center/Blog. (Located at the bottom center of our webpage woodpeck.com.)



WARNING!

This product can expose you to chemicals, including chromium, which is known to the State of California to cause cancer and birth defects or other reproductive harm. For more information go to www.P65Warnings.ca.gov