

SPINRITE®

ROUTER MOTOR

ROUTER MOTOR

WITH REMOTE CONTROL

OWNER'S MANUAL

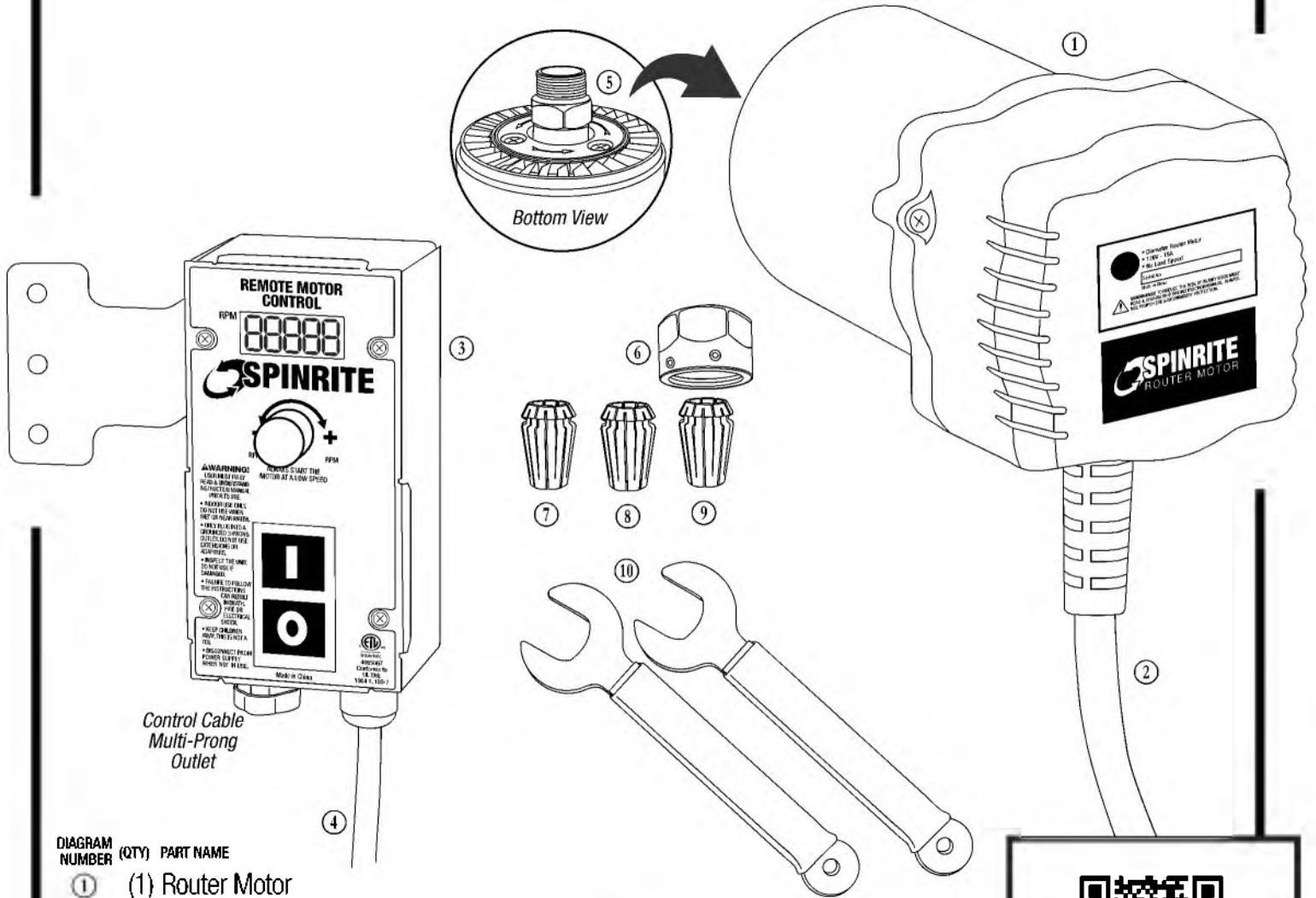

- | DIAGRAM NUMBER | (QTY) | PART NAME |
|----------------|-------|-------------------------|
| ① | (1) | Router Motor |
| ② | (1) | Control Cable |
| ③ | (1) | Remote Motor Controller |
| ④ | (1) | Power Cord 14AWG |
| ⑤ | (1) | Collet Shaft |
| ⑥ | (1) | Collet Nut |
| ⑦ | (1) | 1/4" Collet |
| ⑧ | (1) | 1/2" Collet |
| ⑨ | (1) | 8mm Collet |
| ⑩ | (2) | Collet Wrenches |

WARNING! To reduce the risk of injury keep hands away from moving parts. Refer to your power tool manual for proper setup and use.

WARNING! To reduce the risk of injury, wear safety goggles or glasses with side shields, ear protection & a dust mask.

ETL
 Intertek
 4005867
 Conforms to
 UL Std.
 1004 1, 100-7

Scan the QR code above to watch the video or visit woodpeck.com under the video tab towards the bottom of the product page.

If you think you're missing anything, email us at mailroom@woodpeck.com.
 You can also call us at 800-752-0725 from 9:00 a.m. to 4:00 p.m. EST Monday - Friday.



GENERAL SAFETY RULES

WARNING! READ AND FULLY UNDERSTAND ALL INSTRUCTIONS.

Failure to follow all instructions may result in electrical shock, fire, and/or serious personal injury.

SAVE THESE INSTRUCTIONS. Refer to them often and use them to instruct others.

• PERSONAL SAFETY

1. Know your power tool. Read this manual carefully to learn your power tool's applications and limitations as well as potential hazards associated with this type of tool.
2. Stay alert, watch what you are doing, and use common sense when operating a power tool. Do not use tool while tired or under the influence of drugs, alcohol, or medication. A moment of inattention while operating power tools may result in serious personal injury.
3. Dress properly. Do not wear loose clothing or jewelry. Wear a protective hair covering to contain long hair. These may be caught in moving parts. When working outdoors, wear rubber gloves and insulated non-skid footwear. Keep hands and gloves away from moving parts.
4. Reduce the risk of unintentional starting. Be sure your tool is turned off before plugging it in. Do not use a tool if the power switch does not turn the tool on and off. Do not carry a plugged-in tool with your finger on the switch.
5. Remove all adjusting keys and wrenches. Make a habit of checking that adjusting keys, wrenches, etc. are removed from the tool before turning it on.
6. Do not overreach. Maintain control. Keep proper footing and balance at all times.
7. Use safety equipment. Everyone in the work area should wear safety goggles or glasses with side shields complying with current safety standards. Everyday eyeglasses only have impact resistant lenses. They are not safety glasses. Wear hearing protection during use and a dust mask. Hard hats, face shields, safety shoes, etc. should be used when specified or necessary. Keep a fire extinguisher nearby.
8. Keep guards in place and in working order.
9. Never stand on tool. Serious injury could occur if the tool is tipped or if the cutting tool is tipped or if the cutting tool is unintentionally contacted.
10. Keep hands away from all cutting edges and moving parts.

• ELECTRICAL SAFETY

1. Double insulated tools are equipped with a polarized plug (one blade is wider than the other). This plug will fit in a polarized outlet only one way. If the plug does not fit fully in the outlet, reverse the plug. If it still does not fit, contact a qualified electrician to install a polarized outlet. Do not change the plug in any way. Double insulation eliminates the need for the three-wire grounded power cord and grounded power supply system.
2. Grounded tools must be plugged into an outlet properly installed and grounded in accordance with all codes and ordinances. Never remove the grounding prong or modify the plug in any way. Do not use any adapter plugs. Check with a qualified electrician if you are in doubt as to whether the outlet is properly grounded. If the tool should electrically malfunction or break down, grounding provides a low resistance path to carry electricity away from the user.
3. Guard against electric shock. Prevent body contact with grounded surfaces such as pipes, radiators, ranges and refrigerators. When making blind or plunge cuts, always check the work area for hidden wires or pipes. Hold your tool by insulated nonmetal grasping surfaces. Use a Ground Fault Circuit Interrupter (GFCI) to reduce shock hazards.
4. Do not expose to rain or use in damp locations.
5. Do not abuse the cord. Never use the cord to carry the tools or pull the plug from an outlet. Keep cord away from heat, oil, sharp edges or moving parts. Replace damaged cords immediately. Damaged cords increase the risk of electric shock.

• TOOL USE & CARE

1. Secure work. Use clamps or a vise to hold work when practical. It is safer than using your hand and it frees both hands to operate the tool.
2. Do not force tool. Your tool will perform best at the rate for which it was designed. Excessive force only causes operator fatigue, increased wear and reduced control.
3. Use the right tool. Do not use a tool or attachment to do a job for which it is not recommended.
4. Unplug tool when it is not in use before changing accessories or performing recommended maintenance.
5. Store idle tools. When not in use, store your tool in a dry, secured place. Keep out of reach of children.
6. Never leave the tool running unattended. Turn power off. Do not leave the tool until it comes to a complete stop.
7. Check for damaged parts. Inspect guards and other parts before use. Check for misalignment, binding of moving parts, improper mounting, broken parts and any other conditions that may affect operation. If abnormal noise or vibration occurs, turn the tool off immediately and have the problem corrected before further use. Do not use a damaged tool.
8. Use proper accessories. Consult this manual for recommended accessories. Using improper accessories may be hazardous. Be sure accessories are properly installed and maintained. Do not discard a guard or other safety device when installing an accessory or attachment.
9. Maintain tools carefully. Keep cutting edges sharp and clean. Follow instructions for lubricating and changing accessories. Periodically inspect tool cords and extension cords for damage. Have damaged parts repaired or replaced by the manufacturer.
10. Maintain labels & nameplates. These carry important information.

• WORK AREA

1. Keep work area clean and well lit. Cluttered, dark work areas invite accidents.
2. Avoid dangerous environments. Do not use your power tool in rain, damp or wet locations or in the presence of explosive atmospheres (gaseous fumes, dust or flammable materials). Remove materials or debris that may be ignited by sparks.
3. Keep children and bystanders away. Children and bystanders should be kept at a safe distance from the work area to avoid distracting the operator and contacting the tool or extension cord.
4. Protect others in the work area from debris such as chips and sparks. Provide barriers or shields as needed.
5. Make workshop child proof with padlocks, master switches, or by removing starter keys.

• SERVICE

1. Service performed by unqualified personnel may result in a risk of injury and may void warranty.

• ADDITIONAL WARNINGS

1. **WARNING!** Some dust created by power sanding, sawing, grinding, drilling and other construction activities contains chemicals known by the State of California to cause cancer, birth defects or other reproductive harm.
2. Some examples of these chemicals are: lead from lead-based paint, crystalline silica from bricks and cement and other masonry products, arsenic and chromium from chemically-treated lumber.
3. Your risk from these exposures varies, depending on how often you do this type of work. To reduce your exposure to these chemicals: work in a well-ventilated area, and work with approved safety equipment, such as those dust masks that are specifically designed to filter out microscopic particles.
4. Read, understand, and follow the instructions packaged with the router table and router lift.
5. Always wear safety goggles and dust mask.
6. Use only in a well-ventilated area. Using personal safety devices in a safe environment can reduce the risk for injury.
7. Some woods contain preservatives that can be toxic. Take extra care to prevent inhalation and skin contact when working with these materials. Request, and follow, any safety information available from your material supplier.
8. Always make sure the workpiece is free from nails, screws, and other foreign objects. Keep the working edge away from the clamping surface. Cutting these objects can cause loss of control of the workpiece and damage to the bit.
9. Never place hands near cutting surface.
10. Never use dull or damaged bits. Sharp bits must be handled with care. Damaged bits can break during use. Dull bits require more force, which could cause the bit to break. Damaged bits can throw carbide pieces and burn the workpiece.



GENERAL SAFETY RULES

WARNING!
READ AND FULLY UNDERSTAND ALL INSTRUCTIONS.

• EXTENSION CORDS

Grounded tools require a three-wire extension cord. Double insulated tools can use either a two or three wire extension cord. As the distance from the supply outlet increases, you must use a heavier gauge extension cord. Using extension cords with inadequately sized wire causes a serious drop in voltage, resulting in loss of power and possible tool damage. Refer to the table shown to determine the required minimum wire size.

The smaller the gauge number of the wire, the greater the capacity of the cord. For example, a 14-gauge cord can carry a higher current than a 16-gauge cord. If you are using one extension cord for more than one tool, add the nameplate amperes and use the sum to determine the required minimum wire size.

• GUIDELINES FOR USING EXTENSION CORDS

1. If you are using an extension cord outdoors, be sure it is marked with the "W" designation to indicate that it is acceptable for outdoor use.
2. Be sure your extension cord is properly wired and in good electrical condition. Always replace a damaged extension cord or have it repaired by a qualified person before using it.
3. Protect your extension cords from sharp objects, excessive heat and damp or wet areas.

• RECOMMENDED MINIMUM WIRE GAUGE FOR EXTENSION CORDS*

AMPS	Extension Cord Length in Feet						
	25'-50'	50'-100'	100'-200'	150'-300'	200'-400'	250'-500'	300'-600'
15	16ga	12ga	10ga	8ga	6ga	6ga	4ga

* Based on limiting the line voltage drop to five volts at 150% of the rated amperes.



WARNING! To reduce the risk of injury, always unplug tool before attaching, removing accessories or making adjustments. Use only specifically recommended accessories. Others may be hazardous. Never disassemble the tool or try to do any rewiring on the tool's electrical system.



WARNING! To reduce the risk of injury, electric shock and damage to the tool, never immerse your tool in liquid or allow a liquid to flow inside the tool.



CAUTION! Before each start, check that Router Motor is secure. Ensure that the work is rigidly clamped and secure before making any cuts.

I. ASSEMBLY

A. SELECTING THE BIT

This Router Motor uses an industry-standard ER-20 collet. ⑦ 1/4", ⑧ 8mm, and ⑨ 1/2" are included. ER-20 collets are readily available in fractional inch sizes from 1/16" to 1/2" and in metric sizes from 2mm to 13mm. Any ER-20 collet can be used with this Router Motor. **CAUTION! Do not use router bits with a cutting diameter in excess of 3-1/2".**

A. CHANGING THE COLLET

A Collet must be attached to the Collet Nut before it is put into the Collet Shaft.

STOP Be sure that the size of the Collet matches the size of the bit shank being used. If the wrong size bit shank is used, the Collet may break.

1. Unplug the Router Motor from its power source.
2. To install the desired ⑦ ⑧ ⑨ Collet, insert the Collet into the threaded opening with the flanged end first. Apply firm pressure to the base of the Collet until it snaps in place. You may need to insert it at a slight angle. **FIGURE A.**
3. To remove the Collet from the Collet Nut, press the base of the Collet while pushing the collet from the exposed end until it snaps out of the socket. **FIGURE A-1.**
4. To install on the Router Motor, thread the Collet Nut onto the Collet Shaft. **FIGURE B.**

FIGURE A

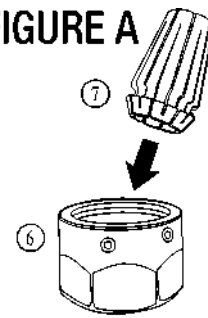

FIGURE A-1

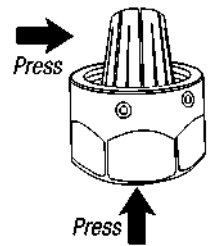
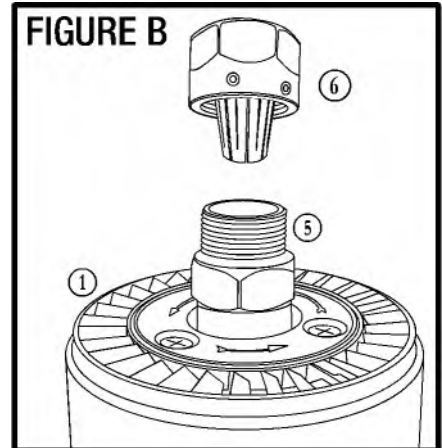

FIGURE B



C. INSTALLING THE BIT

Do not use the Router Motor unless it is securely installed into a recommended router lift and table. To install the Router Motor into a router lift, follow the lift manufacturer's instructions.

It is not necessary to remove the Router Motor from most modern lifts to install a Collet assembly or a bit. The offset wrenches included with this Router Motor assist with certain lifts. If removal of the Router Motor is required, follow the lift manufacturer's instructions.

STOP Never tighten the collet assembly without a bit installed as it may damage the Collet.

1. Unplug the Router Motor from its power source.
2. Raise the Router Motor as high as possible. Always clear any wood chips, dust, or other foreign materials from the Collet Shaft and Collet assembly before installing.
3. Install the desired ⑦ ⑧ ⑨ Collet assembly onto the Collet Shaft.
4. Insert the router bit's shank into the collet and let it drop as far as it can go. **FIGURE C.**
5. Carefully back the shank out slightly to avoid bottoming out. There should be a minimum gap of 1/16" between the Collet assembly and the radius of the cutting head or any flutes of the cutter. **FIGURE C-1.**
6. With the bit sufficiently backed out, hand tighten the Collet Nut until the bit is supported in place.
7. Firmly tighten the ⑥ Collet Nut by placing one collet wrench on the ⑤ Collet Shaft and the other on the ⑥ Collet Nut. Tighten by turning the upper wrench clockwise. The assembly should be tight, but does not need to be forced tight.

FIGURE C

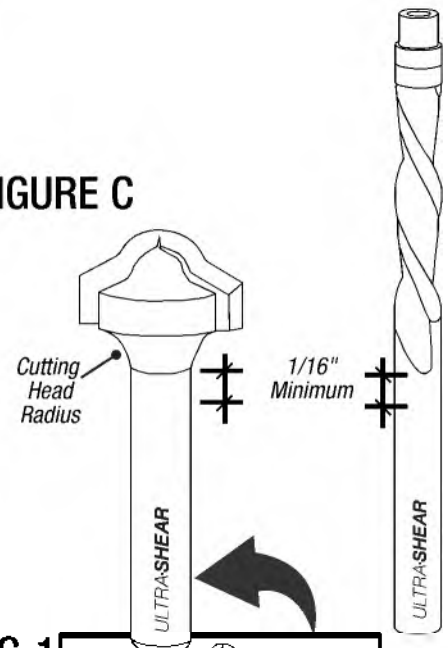
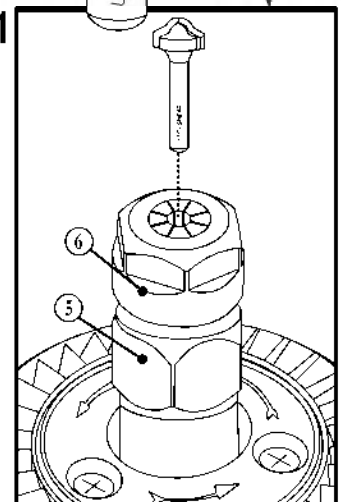

FIGURE C-1



D. REMOVING THE BIT

Always wait for the bit to stop completely and unplug the Router Motor from its power source before changing accessories or making adjustments. Never make adjustments while the Router Motor is running. Do not modify or remove the guards.

To remove the bit, reverse the previous instruction. After the Collet Nut initially breaks free, it will again encounter resistance. Use the collet wrenches to fully loosen the Collet Nut.

E. CONNECTING THE ROUTER TO THE REMOTE CONTROLLER

1. First, determine your desired location to install the remote controller and check that the cord length will work.
 2. Mount the Remote Controller. **FIGURE D.**
 3. With the ① Router Motor installed in your router lift, feed the ② Control Cable from the router to the back of the Remote Controller and plug into the multi-prong outlet.
 4. Plug in the ④ Power Cable to the nearest power outlet in your shop.
 5. Test the Router Motor by pressing the green "ON" button and adjusting the speed control dial. The digital readout will indicate the bit's revolutions per minute (RPM).
-



WARNING! To reduce the risk of injury, always unplug tool before attaching, removing accessories or making adjustments. Use only specifically recommended accessories. Others may be hazardous. Never disassemble the tool or try to do any rewiring on the tool's electrical system.



WARNING! To reduce the risk of injury, electric shock and damage to the tool, never immerse your tool in liquid or allow a liquid to flow inside the tool.



CAUTION! Before each start, check that Router Motor is secure. Ensure that the work is rigidly clamped and secure before making any cuts.

II. FEATURES OF THE ROUTER MOTOR

A. STARTING AND STOPPING THE MOTOR

1. Before starting the Router Motor, always wipe wood chips, dust, or other foreign materials from the Collet Shaft and Collet/Bit Assembly.
2. The soft-start motor reduces the amount of torque reaction on the tool. This feature gradually increases the motor speed from zero to the speed setting. Always allow the motor to reach full speed before engaging the workpiece.
3. Always allow the Router Motor to completely stop before changing the bit or make any adjustments.

A. SPEED CONTROL

1. The SpinRite Router Motor features an external ③ Speed Control Dial with a digital readout.
2. Spinning the Speed Control Dial Clockwise increases the RPM speed (+) while spinning the Speed Control Dial counterclockwise decreases the RPM speed (-) of the bit.
3. Use the chart in **FIGURE E**. for recommended speeds for various diameter bits. Always consult the router bit manufacturer's recommended maximum speeds.

A. ELECTRONIC OVERLOAD PROTECTION

Before the Router Motor is overloaded, the electronic overload protection circuit will turn off the Router Motor.

If the Router Motor stops during use:

1. Turn the power off by pressing the Red "O" Off Power Button.
2. When the bit has completely stopped spinning, clear the Router Bit of any obstructions.
3. Restart the Router Motor by pressing the Green "I" On Power Button.

D. FEEDBACK CONTROL

The Electronic Speed Control System allows the Router Motor to maintain constant speed between no-load and load conditions.

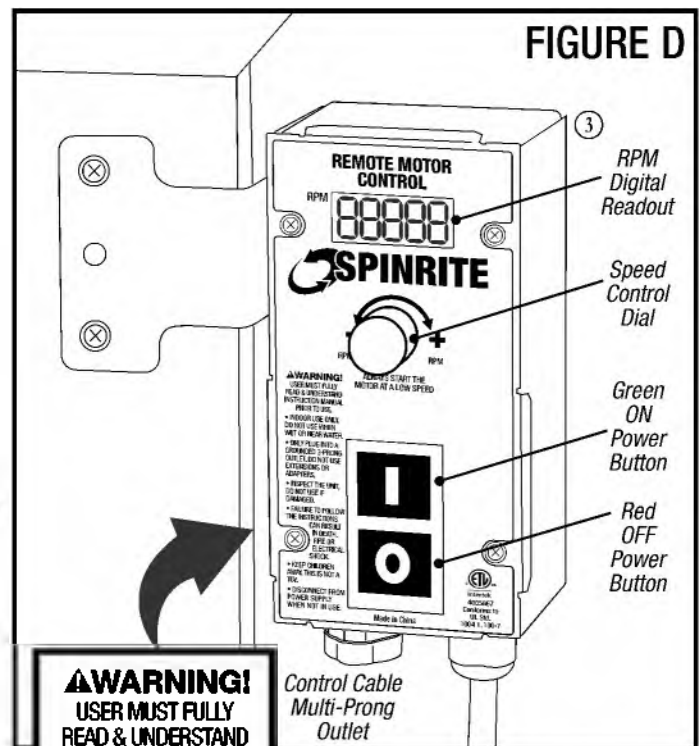

⚠ WARNING! USER MUST FULLY READ & UNDERSTAND INSTRUCTION MANUAL PRIOR TO USE.

- INDOOR USE ONLY. DO NOT USE WHEN WET OR NEAR WATER.
- ONLY PLUG INTO A GROUNDED 3-PRONG OUTLET. DO NOT USE EXTENSIONS OR ADAPTERS.
- INSPECT THE UNIT. DO NOT USE IF DAMAGED.
- FAILURE TO FOLLOW THE INSTRUCTIONS CAN RESULT IN DEATH, FIRE OR ELECTRICAL SHOCK.
- KEEP CHILDREN AWAY, THIS IS NOT A TOY.
- DISCONNECT FROM POWER SUPPLY WHEN NOT IN USE.

FIGURE E

RPM	Maximum Bit Diameter
10,000 to 12,000	3" to 3-1/2"
12,000 to 14,000	2-1/2" to 3"
14,000 to 16,000	2" to 2-1/2"
16,000 to 18,000	1-1/4" to 2"
18,000 to MAX	Min. to 1-1/4"

III. USING THE ROUTER MOTOR

- Before using your router, consider the kind and total amount of material to be removed. It may be necessary, depending on the material, to make more than one cut to avoid overloading the Router Motor. Keep the cutting pressure constant but do not crowd the router so the Router Motor speed slows excessively.
 - Before beginning the cut on the actual workpiece, it is advisable to take a sample cut on a scrap piece of lumber. This will show you exactly how the cut will look as well as enable you to check dimensions.
 - When making cuts on all 4 edges of the workpiece, it is advisable to have the first cut on the end of the workpiece across the grain of the wood. If chipping of the wood occurs at the end of a cut, it will be removed when making the next cut that is parallel with the grain.
 - Position the fence so that the workpiece feeds against the cutter rotation. Feeding the workpiece with the cutter rotation is called climb cutting, which is VERY DANGEROUS. Climb cutting can result in the workpiece being thrown violently out of your control at great speed.
-

IV. MAINTENANCE

Keep your tool in functioning properly by adopting a regular maintenance program. Before use, examine the general condition of your tool. Inspect guards, switches, power cords and extension cord for damage. Check for loose screws, misalignment, binding of moving parts, improper mounting, broken parts and any other condition that may affect its safe operation. If abnormal noise or vibration occurs, turn the tool off immediately and have the problem corrected before further use. Do not use a damaged tool.

Clean dust and debris from vents. Use only soft damp cloth to clean your tool. Never use cleaning agents and solvents such as: gasoline, turpentine, lacquer thinner, paint thinner, chlorinated cleaning solvents, ammonia, household detergents containing ammonia, flammable or combustible solvents around tools. These are harmful to your tool, plastics and insulated parts.

 **WARNING!** To reduce the risk of injury, always unplug tool before attaching, removing accessories or making adjustments. Use only specifically recommended accessories. Others may be hazardous. Never disassemble the tool or try to do any rewiring on the tool's electrical system.

 **WARNING!** To reduce the risk of injury, electric shock and damage to the tool, never immerse your tool in liquid or allow a liquid to flow inside the tool.

 **CAUTION!** Before each start, check that Router Motor is secure. Ensure that the work is rigidly clamped and secure before making any cuts.

SPINRITE® ROUTER MOTOR

ONE YEAR LIMITED WARRANTY

Warrantor warrants to the original purchaser that SpinRite® Router Motor will be free from defects in materials and workmanship under normal use and service for a period of one (1) year from the date of original purchase.

The obligation of this Warranty is limited to repair or replacement, at our option, of components which prove defective under normal use.

Any product or component claimed to be defective should be sent during warranty period, postage prepaid to SpinRite Warranty Department together with a copy of your original dated sales receipt. Please call for authorization number before sending.

This warranty is in lieu of all other express warranties obligations or liabilities. ANY IMPLIED WARRANTIES, OBLIGATIONS OR LIABILITIES, SHALL BE LIMITED IN DURATION TO THE ONE YEAR PERIOD OF THIS LIMITED WARRANTY. NO AGENT, REPRESENTATIVE, DEALER, OR EMPLOYEE OF THE COMPANY HAS THE AUTHORITY TO INCREASE OR ALTER THE OBLIGATIONS OF THIS WARRANTY.

This Warranty shall not apply to any product or component which in the opinion of the Warrantor has been modified or altered in any way, damaged as a result of an accident, misuse or abuse, or loss of parts. In no case shall the Warrantor be liable for any special or consequential damages, or any other costs or warranty, expressed or implied, whatsoever. This Warranty gives you specific legal rights, and you may also have other rights which vary from state to state.

**If you think you're missing anything, call us at
800-752-0725 from 9:00 a.m. to 4:00 p.m. EST Monday - Friday.**



WARNING! To reduce the risk of injury keep hands away from moving parts. Refer to your power tool manual for proper setup and use.



WARNING! To reduce the risk of injury, wear safety goggles or glasses with side shields, ear protection & a dust mask.

SPINRITE® ROUTER MOTOR

© 2025 SpinRite® Brand



WARNING! This product can expose you to chemicals, including chromium, which is known to the State of California to cause cancer and birth defects or other reproductive harm. For more information go to www.P65Warnings.ca.gov