

# Woodpeckers®

## VARIABLE ROUTER JIG

O W N E R ' S M A N U A L

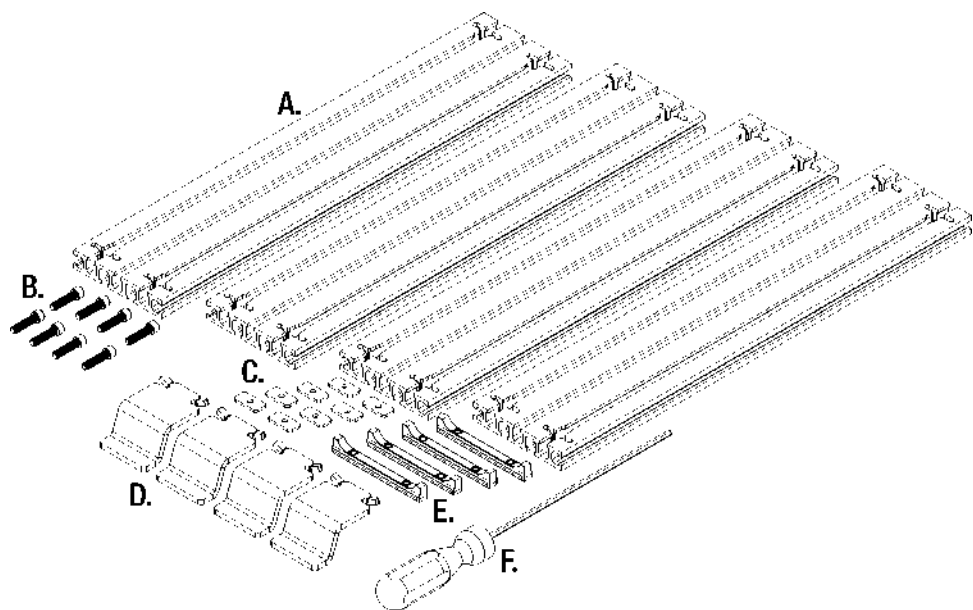

A. (4) Tracks

-Model VRJ-191832 (4) 18" x 32" Tracks

-Model VRJ-19 (4) 18" x 18" Tracks

B. (8) 10/32 x 1" Socket Head Cap Screw (SHCS)

C. (8) Washers

D. (4) Clamp Brackets

E. (4) Lock Bars

F. 5/32" Hex Ball Wrench

The **Woodpeckers Variable Router Jig (VRJ)** enables you to create precise pockets and through cuts in your projects. The VRJ consists of four tracks engraved with both metric and imperial scales, four Lock Bar sets (four bars, eight 10-32 x 1" SHCS and rectangular washers), four clamp brackets, and a Woodpeckers 5/32" hex ball wrench.

If you think you're missing anything, email us at [mailroom@woodpeck.com](mailto:mailroom@woodpeck.com).

You can also call us at 800-752-0725 from 9:00 a.m. to 5:00 p.m. EST Monday - Friday.

## ASSEMBLY

1. The Variable Router Jig (VRJ) utilizes four Lock Bar sets that enable the tracks to be held firmly in place, or slide along to the desired setting. To assemble the jig: Place one of the rectangular washers on one of the 10-32 SHCS and then thread into the Lock Bar a very short amount, as shown. Repeat for the other side of the Lock Bar.

**FIGURE 1**

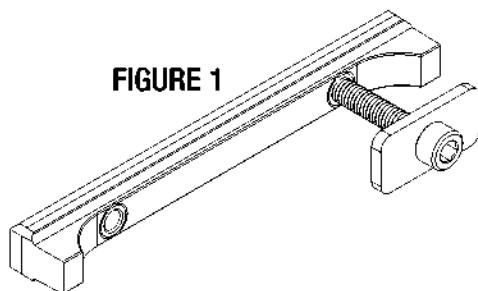

**FIGURE 1**

2. Drop the Lock Bar assembly into the slots on the track.

**FIGURE 2**

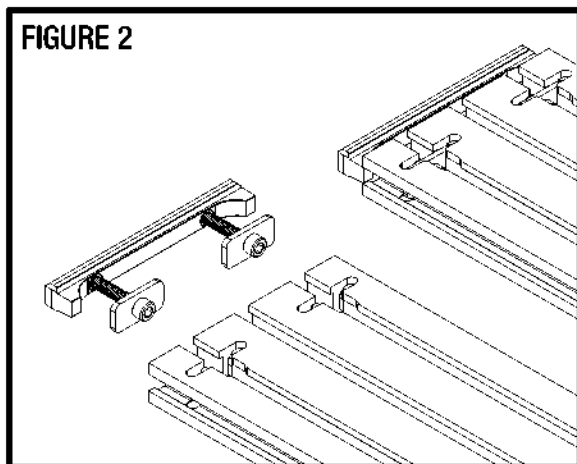

**FIGURE 2**

3. Slide the Assembly into the side of the next track. (Verify you have the proper orientation for the scale you are using).

**FIGURE 3**

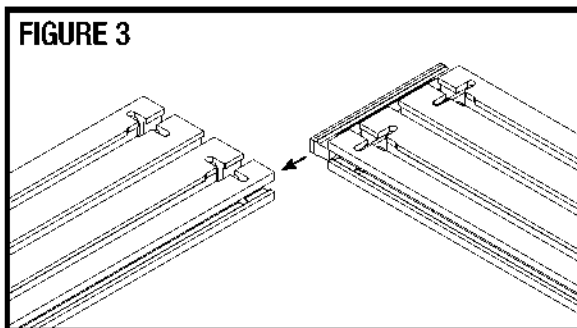

4. Advance the SHCS a few more turns, but do not tighten.

**FIGURE 4**

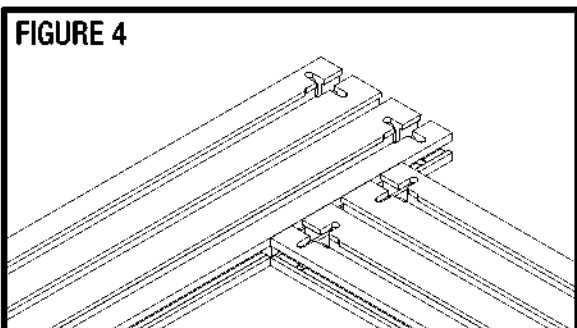

**FIGURE 4**

**FIGURE 5**

5. Repeat for two more tracks. **FIGURE 5**

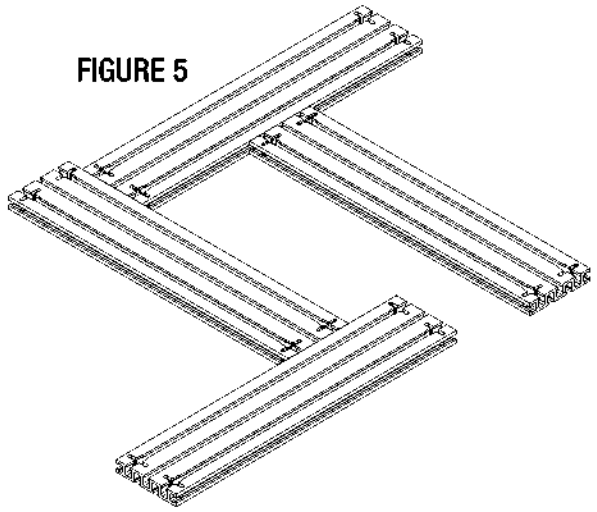

6. For the last track, a slightly different technique must be used. Assemble the washers and SHCS as before, but do not thread into the Lock Bar. Slide the last Lock Bar into the last slot on the side of the track, and then drop the SHCS assemblies into the slots on the track. Move the track to the end to the Lock Bar. Using the supplied 5/32" ball end wrench, attach the two tracks. **FIGURE 6**

**FIGURE 6**

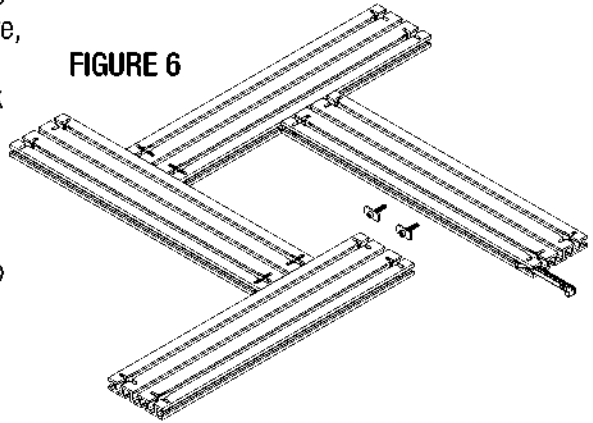

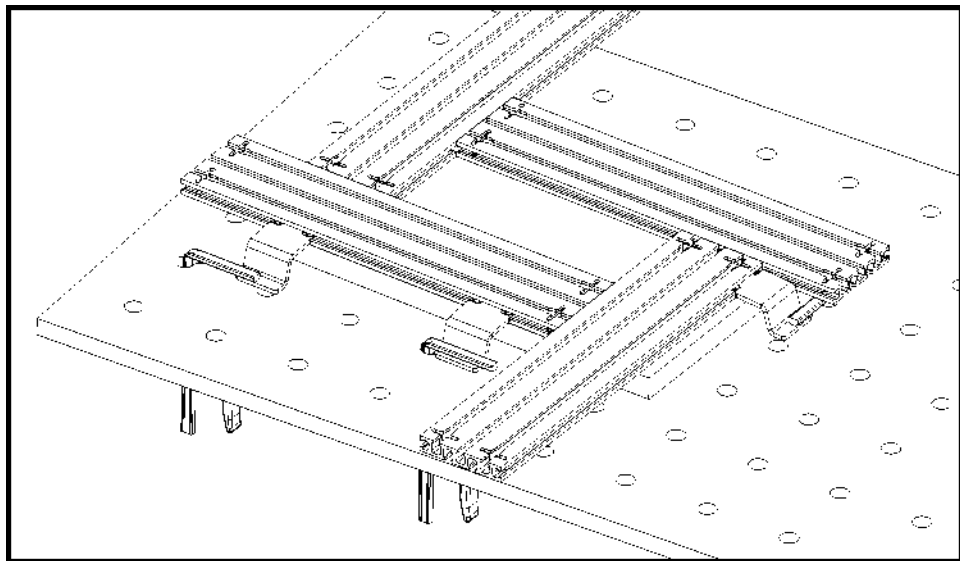

## USING THE VARIABLE ROUTER JIG

1. With the jig assembled, lay out the desired opening. Determine the best router bit and bushing required for your application.
2. Adjust the jig to the required dimensions.
3. Locate the jig and clamp into place.
4. Set the desired depth and rout the pocket/opening. Make sure the router comes to a full stop before removing from the jig. Never allow the router bit to make contact with the jig.
5. Depending on the router, bit, and material used, multiple passes may be required to obtain the desired depth.

# Woodpeckers®

PRECISION WOODWORKING TOOLS MADE IN USA  
Woodpeckers, LLC Strongsville, Ohio · [woodpeck.com](http://woodpeck.com)

© 2019 Woodpeckers, LLC

REV01/22/19



**WARNING!** This product can expose you to chemicals, including chromium, which is known to the State of California to cause cancer and birth defects or other reproductive harm. For more information go to [www.P65Warnings.ca.gov](http://www.P65Warnings.ca.gov)