

Woodpeckers[®]

OneTIME Tool[®]

VICE-LESS WORK SUPPORT

O W N E R ' S M A N U A L

VICE-LESS WORK SUPPORT Sold Separately

DIAGRAM (QTY)

PART NAME

LETTER

- | | | |
|---|-----|-------------------------|
| A | (1) | Adjustable Super Track |
| B | (1) | Fixed Super Track |
| C | (1) | Height Adjustment Knob |
| D | (1) | Upper & Lower Plates |
| E | (1) | Ratcheting Handle |
| F | (2) | Adjustable Height Stops |
| G | (2) | Friction Pad Assemblies |

VICE-LESS WORK SUPPORT SYSTEM Sold Separately

- | | | |
|---|-----|------------------------|
| | (2) | Vise-Less Work Support |
| H | (2) | Track Connector |
| I | (4) | Rectangular Washer |
| J | (4) | 10/32 x 1" SHC Screw |
| K | (1) | 18" Super Track Bridge |
| L | (1) | 5/32" Hex Ball Wrench |

32" BRIDGE for VISE-LESS WORK SUPPORT Sold Separately

- | | | |
|-----|-----|------------------------|
| H | (2) | Track Connector |
| I | (4) | Rectangular Washer |
| J | (4) | 10/32 x 1" SHC Screw |
| N/A | (1) | 32" Super Track Bridge |

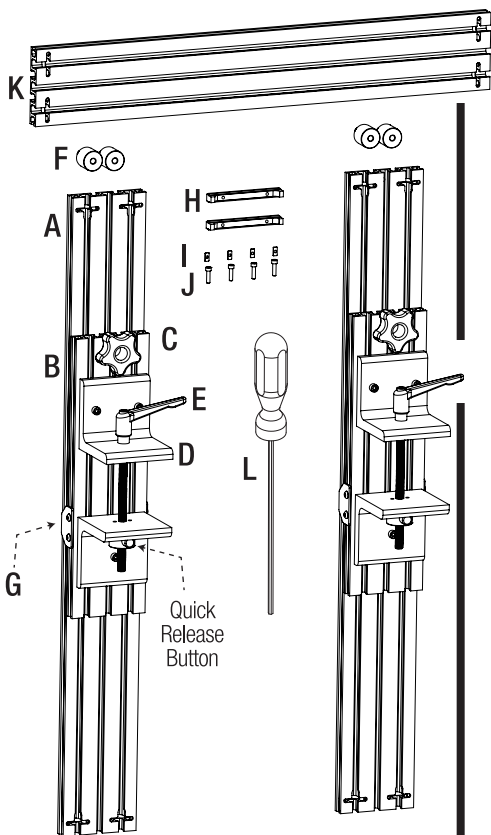

Woodpeckers Vise-Less Work Support attaches to most any horizontal surface to provide an adjustable height clamping platform. It can be used singly or two can be joined with a bridge to form a larger clamping surface.

If you think you're missing anything, email us at mailroom@woodpeck.com.
 You can also call us at 800-752-0725 from 9:00 a.m. to 5:00 p.m. EST Monday - Friday.

ATTACHING THE VISE-LESS WORK SUPPORT

1. Set the Upper Plate on top your bench, table or sawhorse. Depress the Quick-Release Button and raise the Lower Plate until it engages the bottom of whatever you're mounting it on. *Figure 1.*
2. Clamp in place with the Ratcheting Handle. Should you need more than a half-turn, lift up on the Handle, rotate it counter-clockwise, let it back down and it will re-engage.

ADJUSTING THE VISE-LESS WORK SUPPORT

1. Loosen the Height Adjustment Knob. Slide the Adjustable Super Track to the desired position. Tighten the Height Adjustment Knob.

USING THE VISE-LESS WORK SUPPORT

1. Adjust the Adjustable Height Stops along the face of the Adjustable Super Track to support your workpiece at the appropriate position. Be sure your work is positioned so tooling will not come in contact with the Vise-Less Work Support.
2. Use F-clamps, C-clamps or hand-screws to clamp your workpiece to the Vise-Less Work Support.

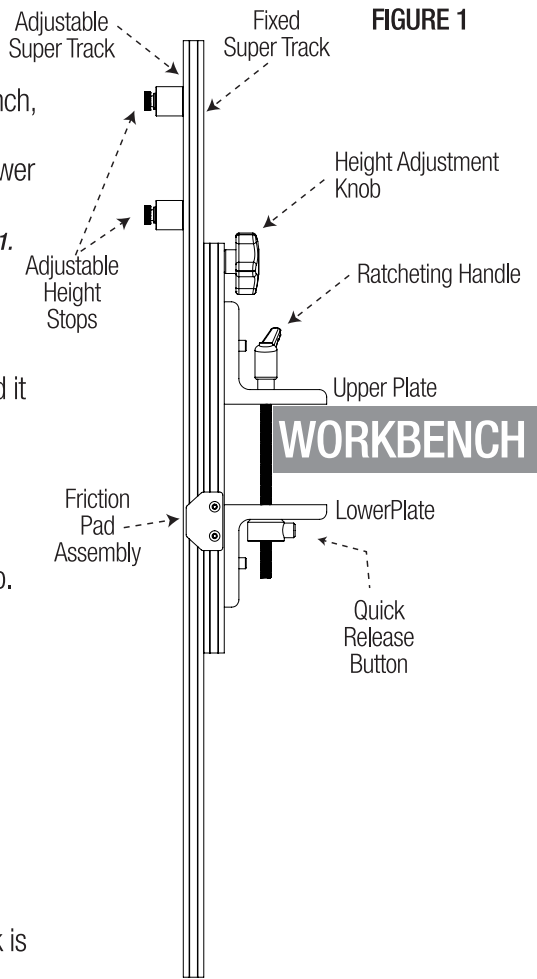

FRICTION PAD ASSEMBLIES

1. Slide the Friction Pad Assemblies up the slot of the Fixed Super Track. *Figure 2.*
2. Set the edge of the Friction Pad Assembly 3-1/2" from the edge of the Fixed Super Track.
3. Secure the Friction Pad Assembly by turning the knob. Finger tighten only, do not overtighten. *Figure 3.*

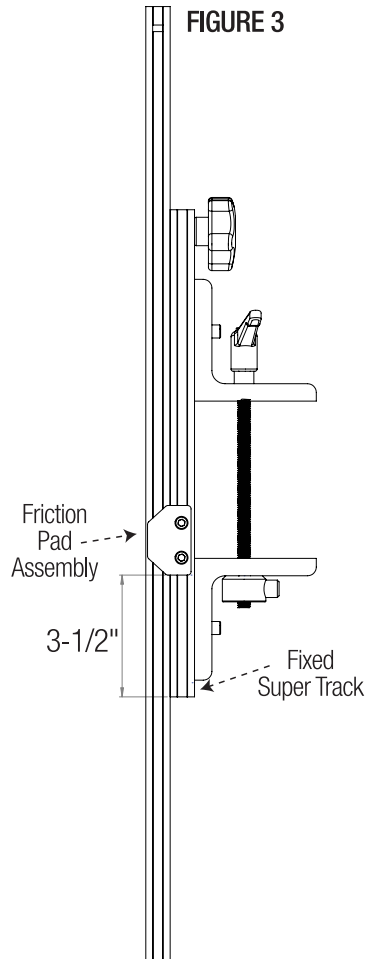
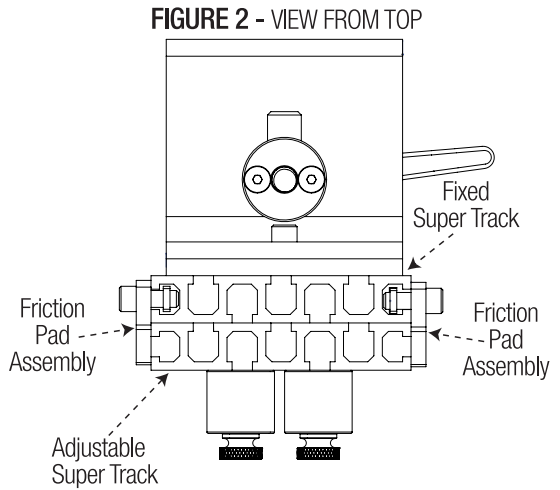

JOINING TWO VISE-LESS WORK SUPPORTS, SOLD SEPARATELY

To join two Vise-Less Work Supports, assemble the Track Connectors as shown in *Figure 4*. Drop the Rectangular Washers and 10/32 x 1" SHC Screws into the slotted ends of the Bridge (either 18" or 32")

Slide the Track Connectors into the edges of the Adjustable Super Tracks. Lock the Track Connectors at any convenient position along the Super Track. *Figure 5*.

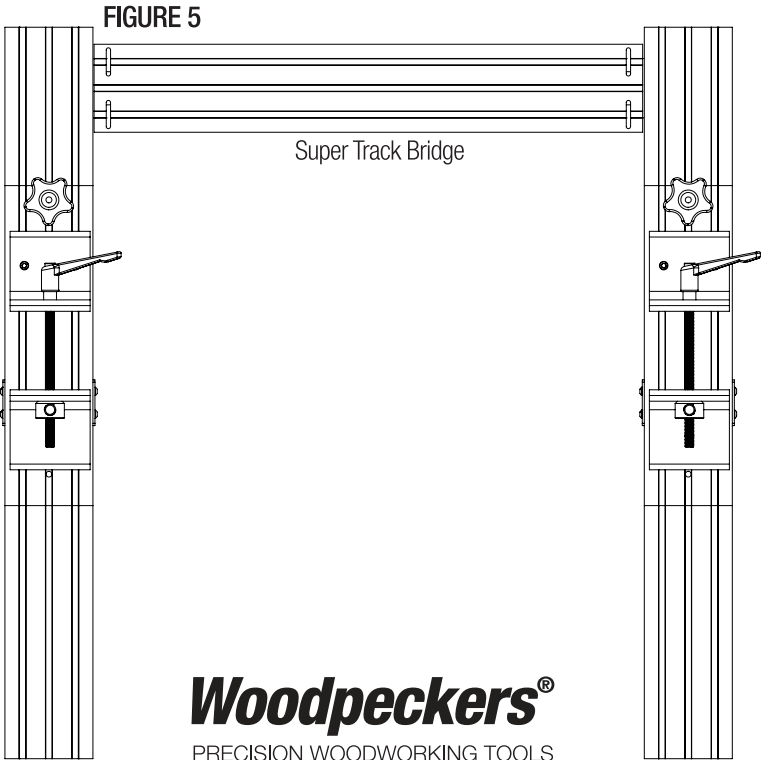
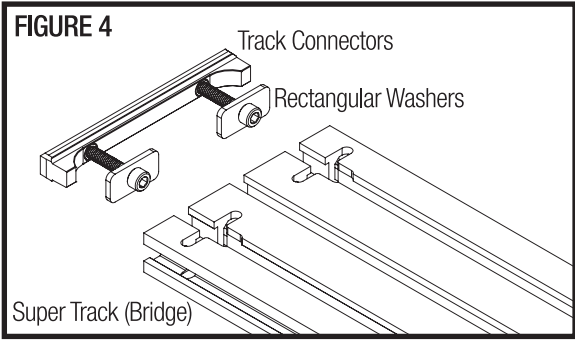

REV100720



WARNING! This product can expose you to chemicals, including chromium, which is known to the State of California to cause cancer and birth defects or other reproductive harm. For more information go to www.P65Warnings.ca.gov