

Woodpeckers[®]

PARALLEL GUIDE SYSTEM

OWNER'S MANUAL

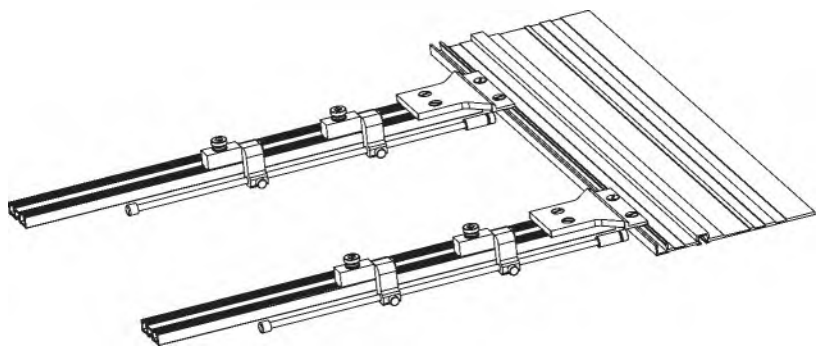

Woodpeckers Parallel Guide System (PGS) provides effortless repetitive cuts when paired with Festool's* Guide Rail and Track Saw. Using a physical stop, just like a table saw rip fence, each cut is exactly the same as the one before.

**Also works with Makita and Triton.*

- A. (2) Main Body Brackets
Including Mounting Hardware
 - a-1. (4) 1/4-20 x 5/8" Machine Screws
 - a-2. (4) 1/4-20 x 3/8" Machine Screws
 - a-3. (4) Oval Nuts
 - a-4. (2) Bracket Fixtures
- B. (4) Flip Stops
- C. (8) Laser Engraved, Dual Purpose Tracks with Scales
- D. 6 T-Track Connectors
 - d-1. 1/8" Hex Key
- E. 2 Narrow Stock Guides with
 - e-1. (2) Rod Stop
 - e-2. (2) Plastic Tip

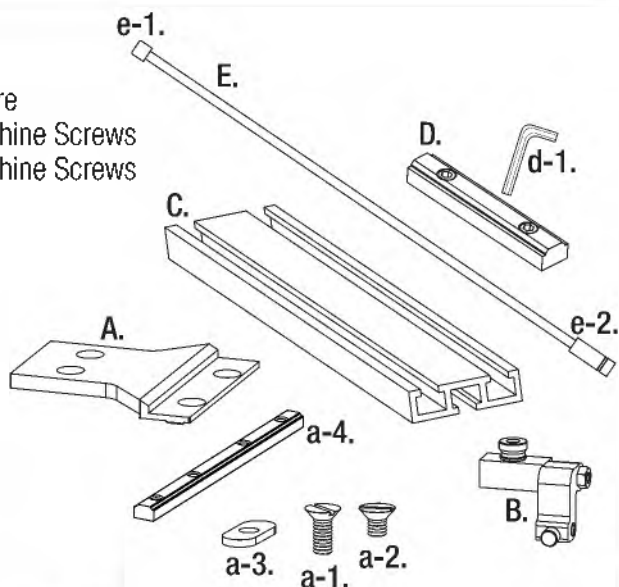

If you think you're missing anything, email us at mailroom@woodpeck.com.
You can also call us at 800-752-0725 from 9:00 a.m. to 5:00 p.m. EST Monday - Friday.

ASSEMBLY

1. The Parallel Guide System includes eight sections of extruded aluminum Track (C) and six T-Track Connectors (D). When properly assembled you will have two 48" long tracks with identical continuous calibrations. To join the tracks, center the connectors between two tracks, be sure the ends meet flush and secure the set screws using the 1/8" Hex Key. **FIGURE 1**

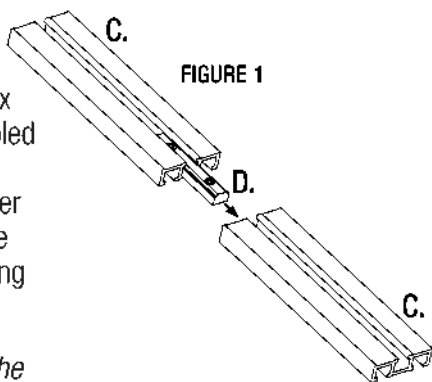

Tip: Only assemble the sections you need for the cuts you're making. There's no advantage to using the fully assembled tracks unless they're necessary.

2. The Main Body Brackets (A) connect the two Tracks (C) to your guide rail. Insert the two 1/4-20 x 5/8" Machine Screws (a-1) into the narrow, thick end of the Main Body Bracket (A). Start an Oval Nut (a-3) on each. Insert the two 1/4-20 x 3/8" Machine Screws (a-2) in the thin wide end of the Main Body Bracket (A) and start them into the two center holes in the Bracket Fixture (a-4). **FIGURE 2**

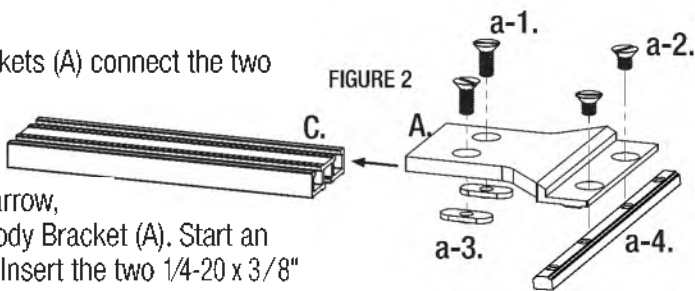

3. Insert the two Oval Nuts (a-3) into the two slots of each Track (C) and slightly tighten the screws to hold the Tracks to the Main Body Bracket. (These screws will be fully tightened later during the calibration step.) Slide the Bracket Fixture into the edge slot of your guide rail. **FIGURE 3-3a** Position as desired. Lock the Bracket Fixture in place with the two outside set screws then tighten the two center screws.

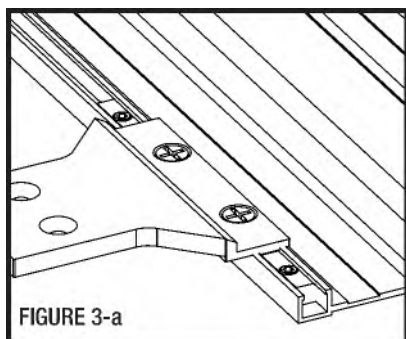
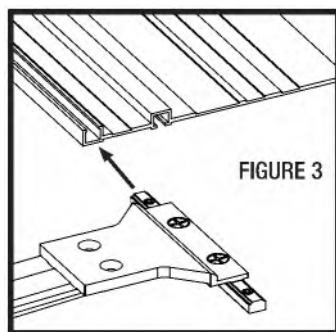

CALIBRATION

4. Install two Flip Stops (B) on each Track. Stops should be in the groove below the scale. Flip the stops all the way up. Align the right stop to the 11-5/8" mark (indicated on the scale with an arrow). Align the left stop to the 14-5/8" mark (also indicated with an arrow). **FIGURE 4**

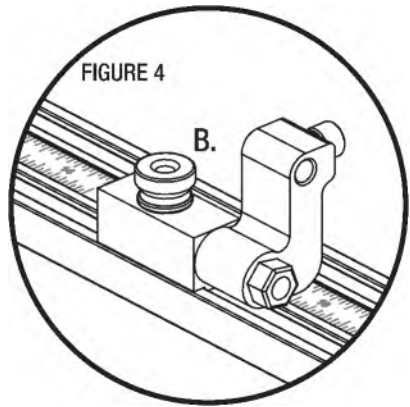

5. Insert the stainless steel Narrow Stock Guide (E) through the openings of the Flip Stop arms (B). **FIGURE 5** Install the Plastic Tip (e-2) on the end of the Narrow Stock Guide Tip (e-2) on the end of the Narrow Stock Guide (E) that is pointing toward the guide rail. Install the Rod Stop (e-1) on the other end. Move the rod all the way to the right until the Rod Stop contacts the left Flip Stop. Tighten the small knobs on the Flip Stops to secure the Narrow Stock Guide rod. Repeat the process to install the other Narrow Stock Guide on the second arm.

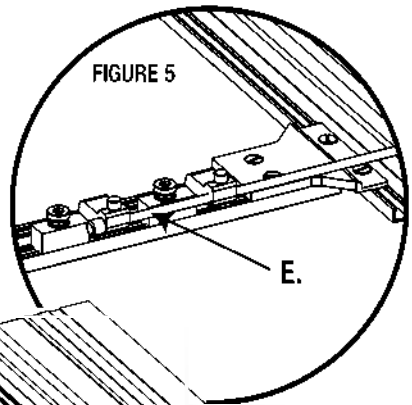

6. At this point the Main Body Bracket (A) should be tight on the saw guide rail and the Narrow Stock Guides (E) tight in the Flip Stops (B). The two Parallel Guide System Arms should be loosely connected to the Main Body Bracket (A).

7. Position a perfectly square reference against the cut line of your guide rail.

Carefully move the Track in or out of the Body Bracket until the tip of the Narrow Stock Guide just touches the square reference. **FIGURE 6** Tighten the two Machine Screws (a-1) to secure the Track to the Main Body Bracket. Repeat the calibration steps for the other Parallel Guide System Arm.

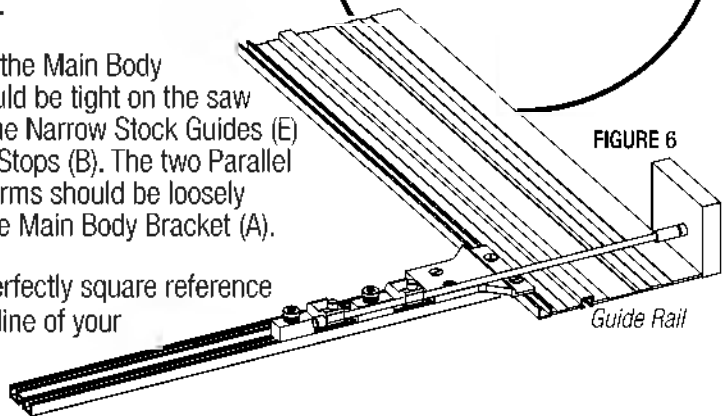

USING THE PARALLEL GUIDE SYSTEM (PGS) FOR NORMAL CUTTING (10-1/2" or greater)

Flip your Flip Stops all the way up. Position the right end of the Flip Stop at your desired measurement. Repeat on the second Track. Drop the Flip Stops into the lower position. Position both stops firmly against the edge of your stock and make the cut.

USING THE PGS FOR NARROW CUTTING (10-1/2" or less)

To make narrow cuts, the Narrow Stock Guides have to be under the saw Guide Rail. It will be necessary to support the opposite end of the PGS Tracks with stock the same thickness as the stock being cut.

Install the Narrow Stock Guides into the Flip Stops as described in step 5 on page 3 of this booklet.

Loosen the knurled lock knob on the Flip Stop closest to the saw Guide Rail. With both flip stops down, move the right Flip Stop to the right and position it close to the Main Body Bracket. Adjust the left Flip Stop to your desired dimension **referencing the scale on the side of the Track**. Move the Narrow Stock Guide to the right until the Rod Stop contacts the left side of the left Flip Stop. Lock the rod in place in both Flip Stops and repeat the process on the second Arm. When done, you are ready to make your cut.

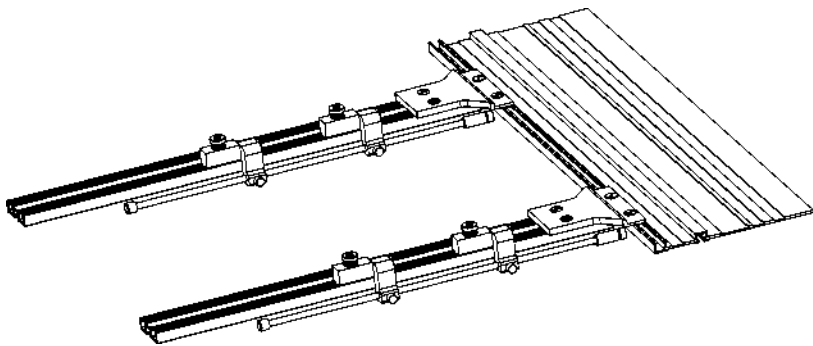

Woodpeckers®

PRECISION WOODWORKING TOOLS

Woodpeckers, LLC Strongsville, Ohio · woodpeck.com

© 2019 Woodpeckers, LLC

REV001619



WARNING! This product can expose you to chemicals, including chromium, which is known to the State of California to cause cancer and birth defects or other reproductive harm. For more information go to www.P65Warnings.ca.gov