

Woodpeckers[®]

HOLE BORING JIG

O W N E R ' S M A N U A L

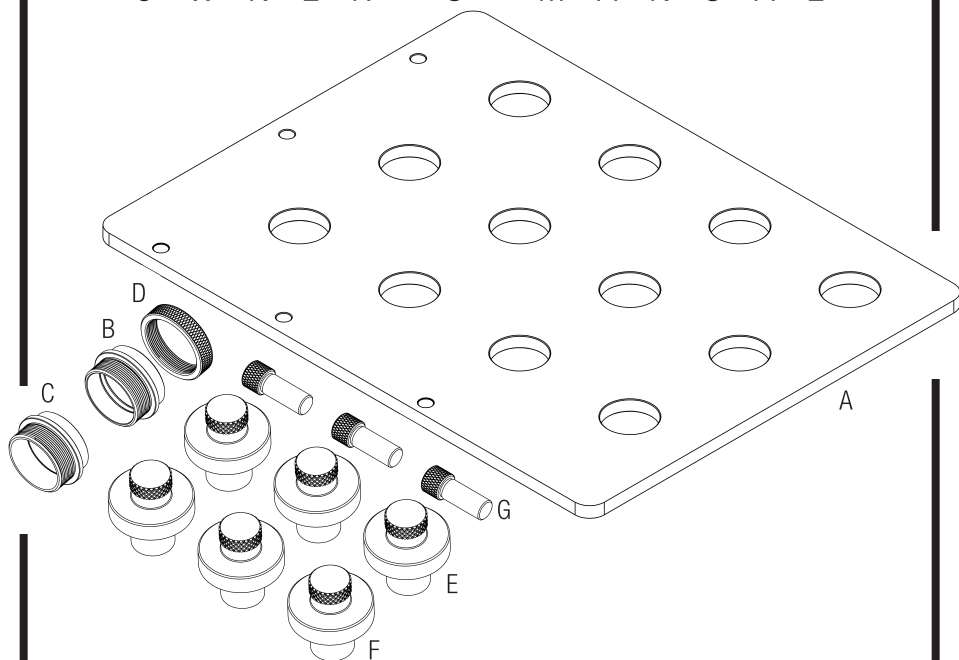

HOLE BORING JIG SET

DIAGRAM (QTY) PART NAME
LETTER

- | | |
|---|-------------------------------|
| A | (1) Hole Boring Template |
| B | (1) 3/4" Guide Bushing |
| C | (1) 20mm Guide Bushing |
| D | (1) Locking Ring |
| E | (3) 3/4" (.750) Indexing Pins |
| F | (3) 20mm Indexing Pins |
| G | (3) Edge Locating Pins |

HOLE BORING JIG 3/4" ONLY

DIAGRAM (QTY) PART NAME
LETTER

- | | |
|---|-------------------------------|
| A | (1) Hole Boring Template |
| B | (1) 3/4" Guide Bushing |
| D | (1) Locking Ring |
| E | (3) 3/4" (.750) Indexing Pins |
| G | (3) Edge Locating Pins |

HOLE BORING JIG METRIC ONLY

- | | |
|---|--------------------------|
| A | (1) Hole Boring Template |
| C | (1) 20mm Guide Bushing |
| D | (1) Locking Ring |
| F | (3) 20mm Indexing Pins |
| G | (3) Edge Locating Pins |

If you think you're missing anything, email us at mailroom@woodpeck.com.
You can also call us at 800-752-0725 from 9:00 a.m. to 5:00 p.m. EST Monday - Friday.

The **Woodpeckers Hole Boring Jig** lets you create a replacement top for your Festool® MFT or create a custom table of any size with the same 96mm center-to-center hole spacing. All you need is a plunge router that accepts Porter-Cable® style guide bushings and a 1/2" straight cut router bit.

TO MACHINE A GRID TABLE TOP:

1. Obtain and size the material for the top.
2. Place the **Edge Locating Pins** into the **Hole Boring Template**. Make sure that two of the **Edge Locating Pins** are as close to the corner as shown (FIGURE A), and the third is as far from the corner as possible.
3. Verify that all three **Edge Locating Pins** are in contact with the material. Then clamp the **Hole Boring Template** into place. (FIGURES B & C)

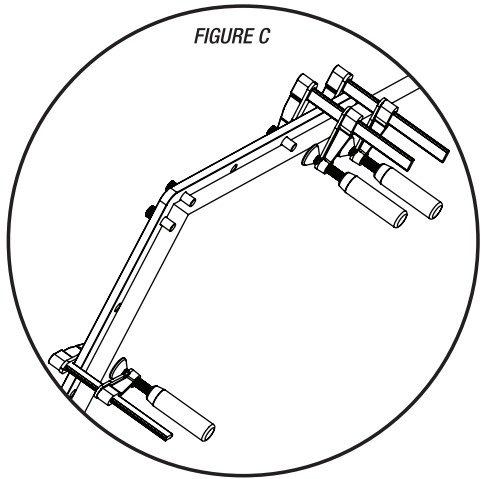
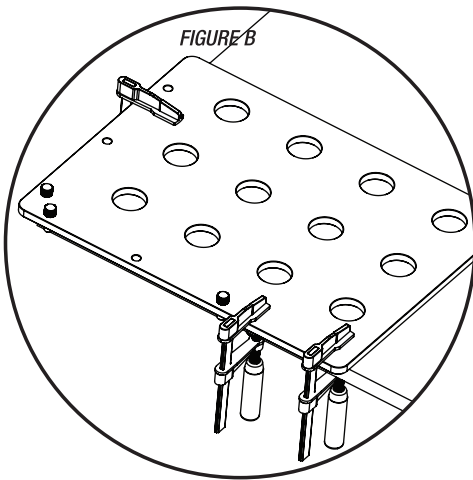
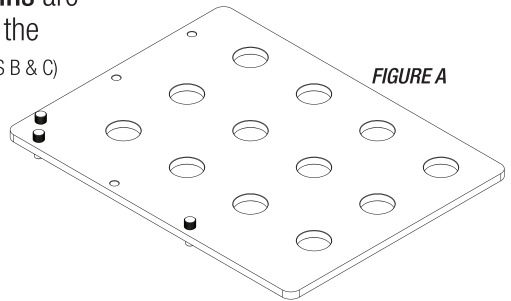

4. Attach the appropriate **Guide Bushing** to your router. For 2096 (MFT Table) hole size and spacing, use the **Bushing** that has a single groove on the inside diameter. (The two-groove **Bushing** is for 3/4" (.750") holes). (FIGURE D)

FIGURE D Single Groove Guide Bushing for 20mm Holes

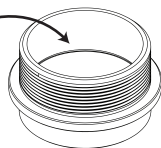

Double Groove Guide Bushing for 3/4" (.750") Holes

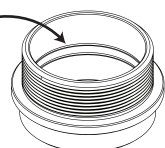

5. Install a 1/2" diameter router bit into your router and set the desired depth. Take into account the 3/8" thickness of the **Hole Boring Template**.
6. Determine the holes that can be routed based on the clamp placement.
7. Place the router bushing in one of the accessible holes and plunge. The plunge depth is dependent upon the material being used for the table top, the router, and quality of the router bit.
8. Cut the full circle. (FIGURE E)

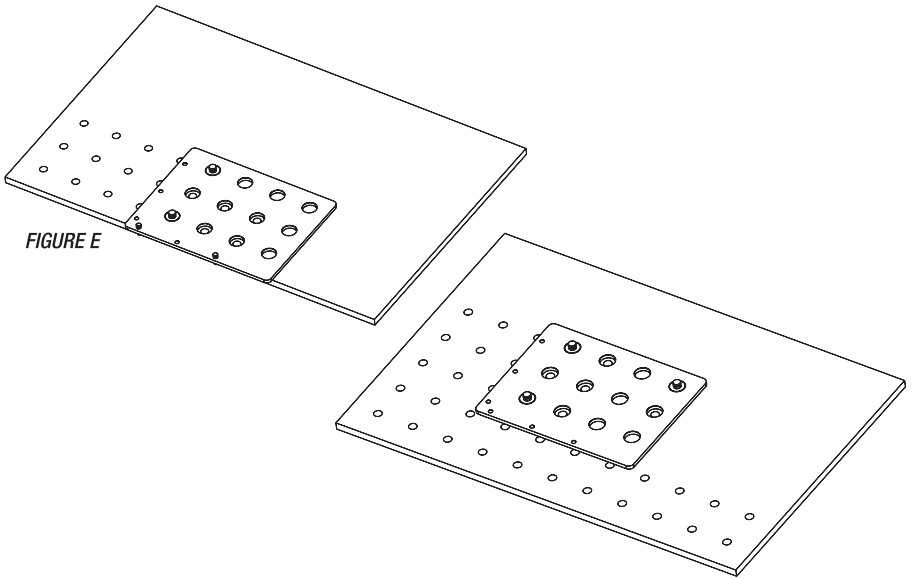

9. Let the router come to full stop before moving to a new location.

NOTE: MDF and other materials can swell once they are cut. In order to maintain the highest degree of accuracy, it is recommended that the holes be recut before moving the template to a new location.

Using the template to cut 3/4" (.750) holes is the exact same steps as shown above. The only difference is that you would use the double-grooved **3/4" (.750) Guide Bushing** and the **3/4" (.750) Indexing Pins**.

REV090319

Woodpeckers[®]

PRECISION WOODWORKING TOOLS

Woodpeckers, LLC Strongsville, Ohio · ***woodpeck.com***

© 2019 Woodpeckers, LLC



WARNING! This product can expose you to chemicals, including chromium, which is known to the State of California to cause cancer and birth defects or other reproductive harm. For more information go to www.P65Warnings.ca.gov