

Woodpeckers®

Xpander CLAMP SYSTEM

OWNER'S MANUAL

- Xpander 24/30 Compatible with Parallel Jaw Clamps from 24" to 40"
 - Xpander 40/50 Compatible with Parallel Jaw Clamps from 40" to 50"
- Models & Clamps Sold Separately

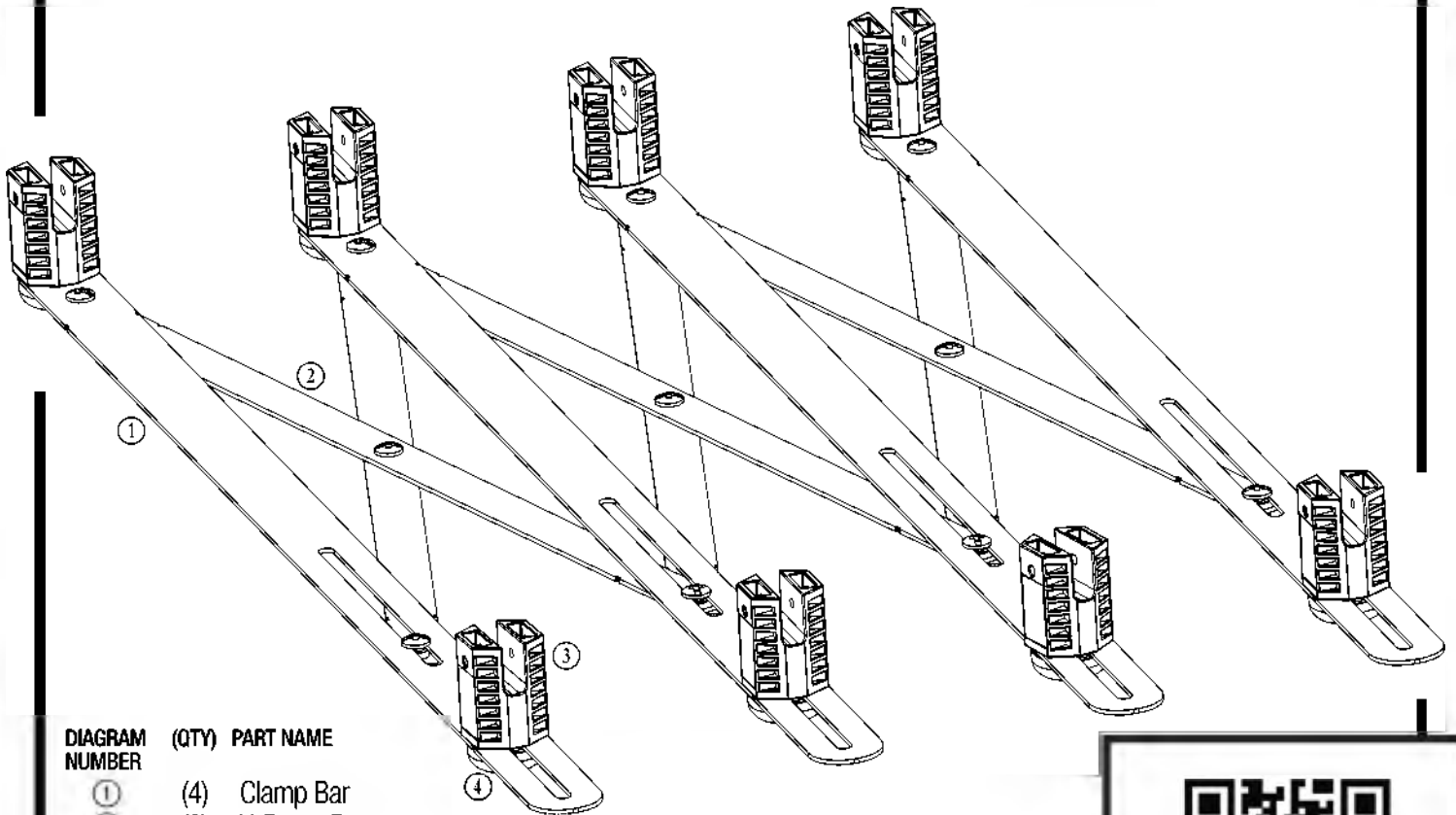

DIAGRAM NUMBER	(QTY)	PART NAME
①	(4)	Clamp Bar
②	(6)	X-Brace Bars
③	(8)	Clamp Holder
④	(8)	Slider

HARDWARE BAG

- (16) Clamp Holder Set Screw, 1/4-20
- (11) Barrel Bolt, Top & Bottom, 1/4-20
- (8) Shoulder Bolt, 1/4-20
- (7) Thick Washer A, .250
- (15) Thin Washer B, .032



Scan the QR code above to watch the video or visit woodpeck.com under the video tab towards the bottom of the product page.

If you think you're missing anything, email us at mailroom@woodpeck.com.
You can also call us at 800-752-0725 from 9:00 a.m. to 4:00 p.m. EST Monday - Friday.

A NOTE BEFORE YOU START ASSEMBLY: Pay close attention to the order of the washers during assembly. Different combinations of washers are used at different parts to ensure that the tool is level and opens and closes smoothly.

YOU WILL NEED: (2) #2 Phillips head screwdrivers, 1/8" Allen Wrench (Not Included.)

1. Layout the (6) X-Brace Bars ② as shown in **Figure A**. (3) X-Brace Bars slanted to the right (shown in grey) and (3) X-Brace Bars (shown in white) on top slanted to the left forming the X-Brace.

x3 CENTER LOCATIONS

- Barrel Bolt, Top
- Center Bar ②
- Thin Washer B
- X-Brace Bar ②
- Thick Washer A
- Barrel Bolt, Bottom

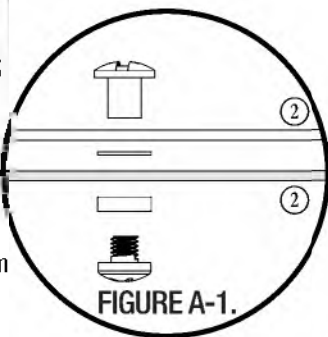

FIGURE A-1.

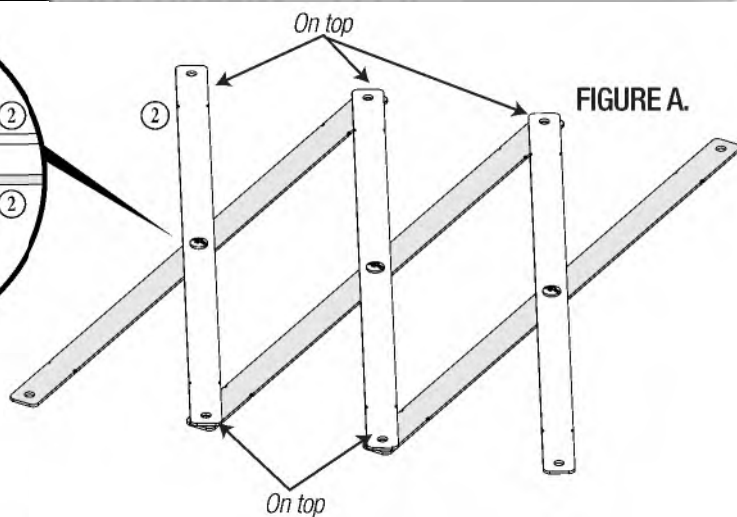

FIGURE A.

2. Secure the (3) top X-Brace Bars to the (3) bottom X-Brace Bars at all (3) center intersecting points with the Barrel Bolt and Washers. **Figure A-1.**

3. Place (2) Clamp Bars ① on top of the X-Brace ② where the X-Brace Bars intersect in the four locations.

4. Attach using the Barrel Bolts and Thin Washers. **Figures B-1 & B-2.**

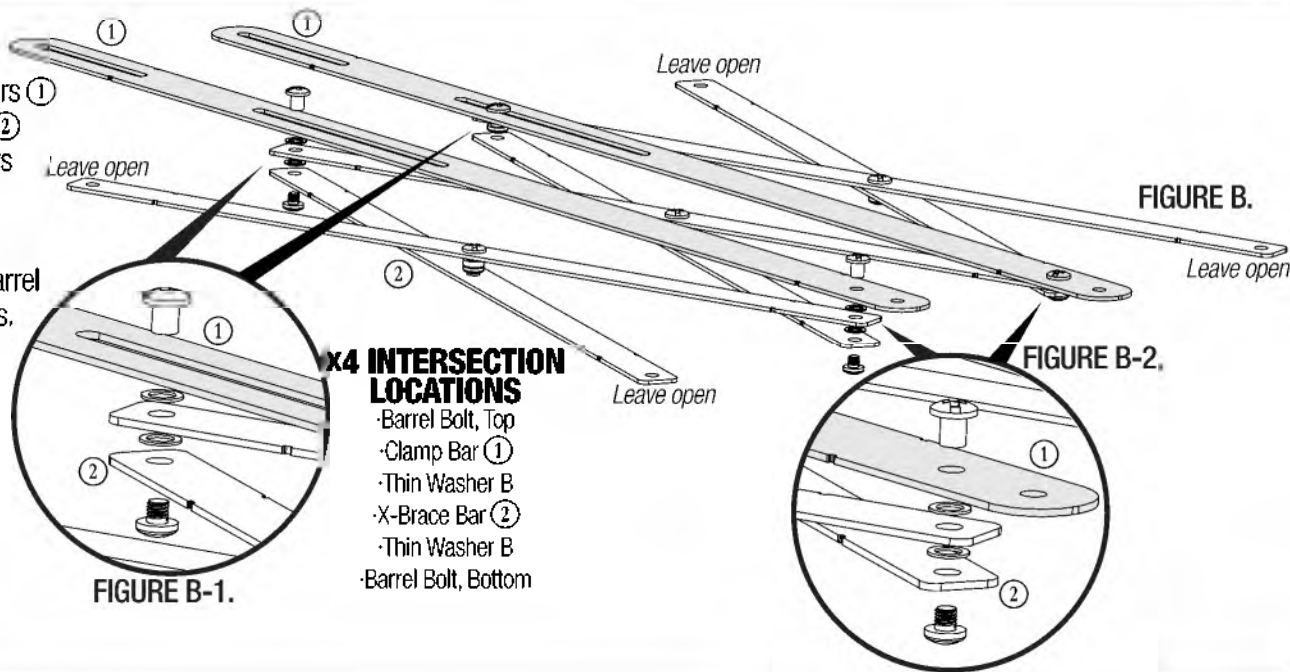

FIGURE B.

x4 INTERSECTION LOCATIONS

- Barrel Bolt, Top
- Clamp Bar ①
- Thin Washer B
- X-Brace Bar ②
- Thin Washer B
- Barrel Bolt, Bottom

FIGURE B-1.

FIGURE B-2.

- A**
- Barrel Bolt, Top
 - Clamp Bar ①
 - Thick Washer A
 - X-Brace Bar ②
 - Thin Washer B
 - Barrel Bolt, Bottom

FIGURE C.

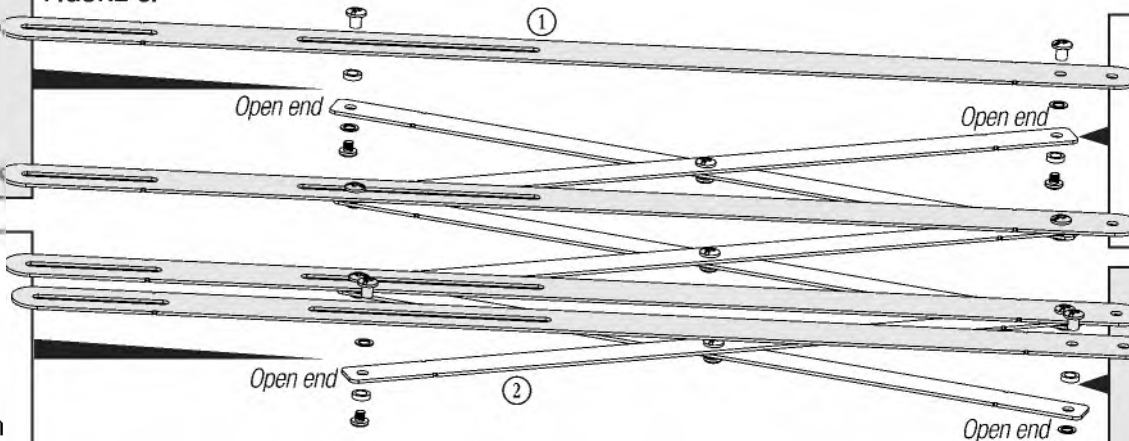

- B**
- Barrel Bolt, Top
 - Clamp Bar ①
 - Thin Washer B
 - X-Brace Bar ②
 - Thick Washer A
 - Barrel Bolt, Bottom

- B**
- Barrel Bolt, Top
 - Clamp Bar ①
 - Thin Washer B
 - X-Brace Bar ②
 - Thick Washer A
 - Barrel Bolt, Bottom

- A**
- Barrel Bolt, Top
 - Clamp Bar ①
 - Thick Washer A
 - X-Brace Bar ②
 - Thin Washer B
 - Barrel Bolt, Bottom

5. Place the (2) Clamp Bars ① at each open end of to the X-Brace ②. **Figure C.**

6. Follow the chart above to attach the Barrel Bolts and Washers. *The opposing corners should have the same hardware order.*

7. Install the (8) Clamp Holders ③ and (8) Sliders ④ on the end of each Clamp Bar assembly with a (8) Shoulder Bolts. **Figure D.**

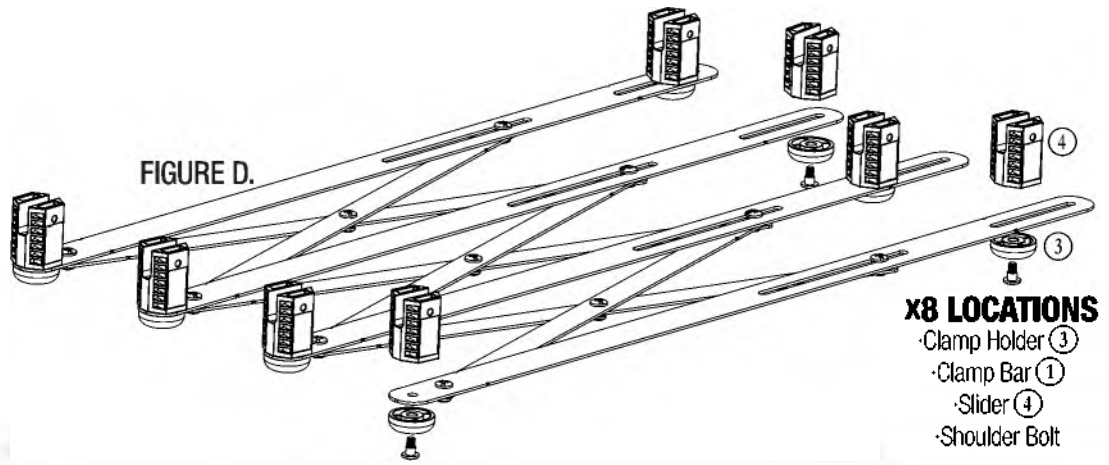

8. Install the (16) Clamp Holder Set Screws into the Clamp Holders ③ using a 1/8" Allen Wrench. **Figure E.**

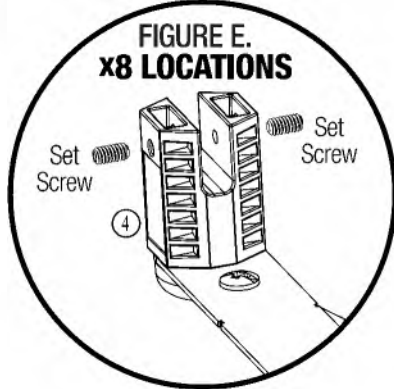

9. Tighten the Set Screws to lock the clamp firmly in place.

USING THE XPANDER

Clamps can be installed with the handle end of the clamp on either the inside (**Figure F.**) or outside (**Figure G.**) of the Clamp Holder depending on the length of your clamp and the width of your panel.

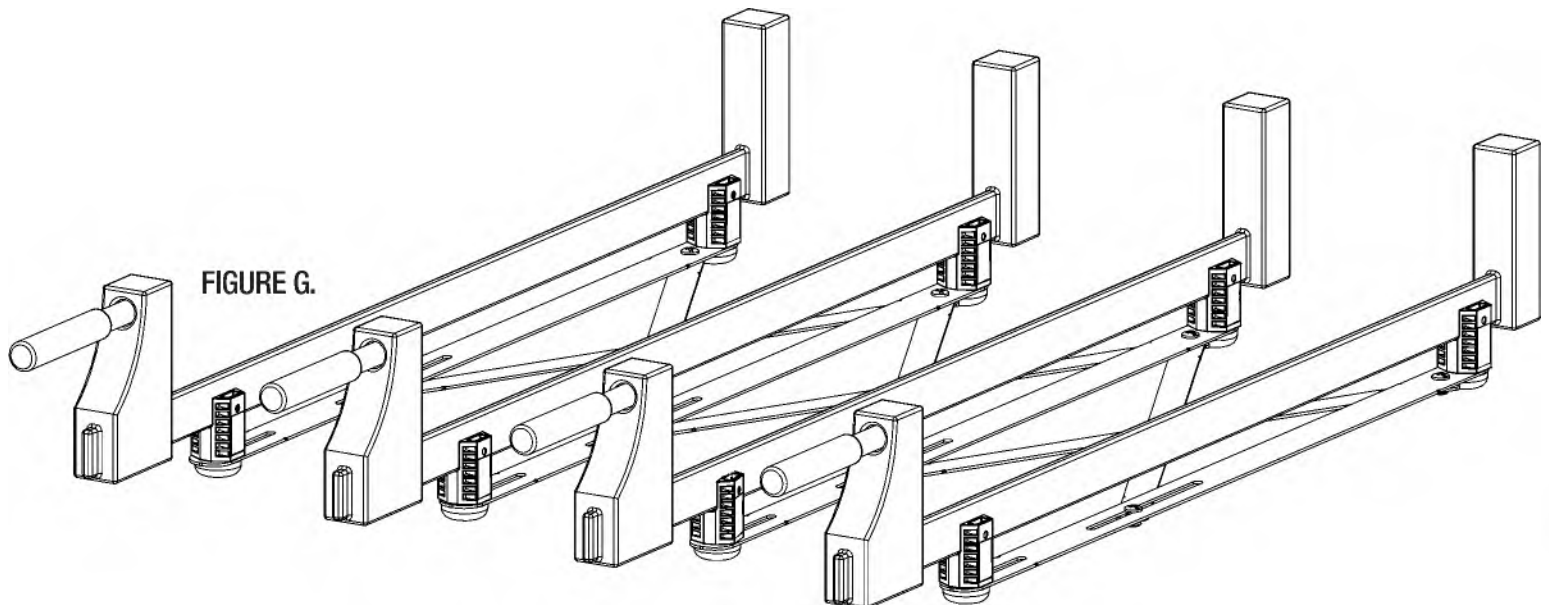
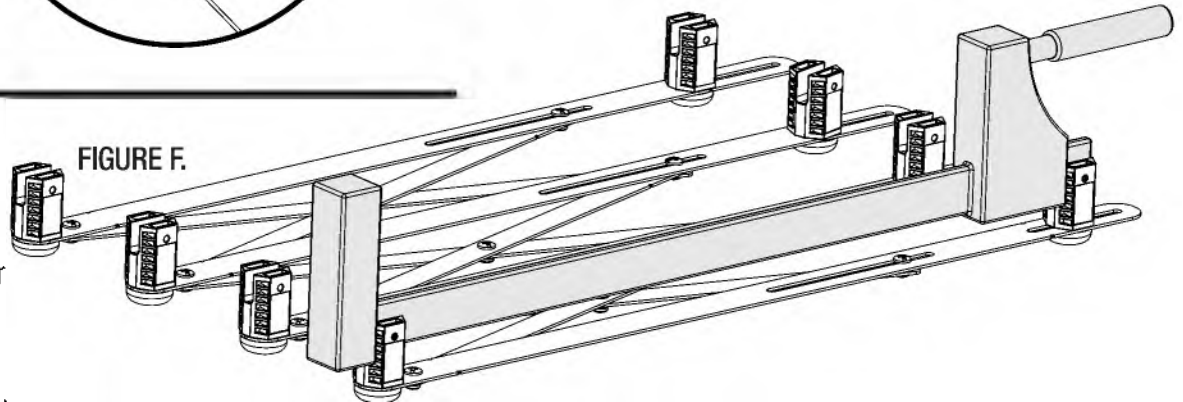

Woodpeckers®

Woodpeckers, LLC Strongsville, Ohio

woodpeck.com

© 2022 Woodpeckers, LLC



woodpeck.com

At Woodpeckers we are constantly reviewing & improving our tools. The most current version of our instruction manuals are always available to download at woodpeck.com.

(Located in the bottom section of the tool's page under the "Additional Information" or "Instructions" tabs.)



Be the first to know all the new products, OneTIME Tools & sales by subscribing to our eClub. *(Located at the top center of our webpage woodpeck.com.)*



Subscribe to our YouTube channel to stay up-to-date on all the latest tool tips & tricks.



INTERACT WITH US! Follow us on Facebook, Instagram & TikTok!



Enjoy shop tips, project ideas, tool techniques & more in our Woodworking Resource Center/Blog. *(Located at the bottom center of our webpage woodpeck.com.)*



WARNING!

This product can expose you to chemicals, including chromium, which is known to the State of California to cause cancer and birth defects or other reproductive harm.

For more information go to www.P65Warnings.ca.gov