

Woodpeckers®

6-IN-1 POCKET & SHOP GAUGES

OWNER'S MANUAL

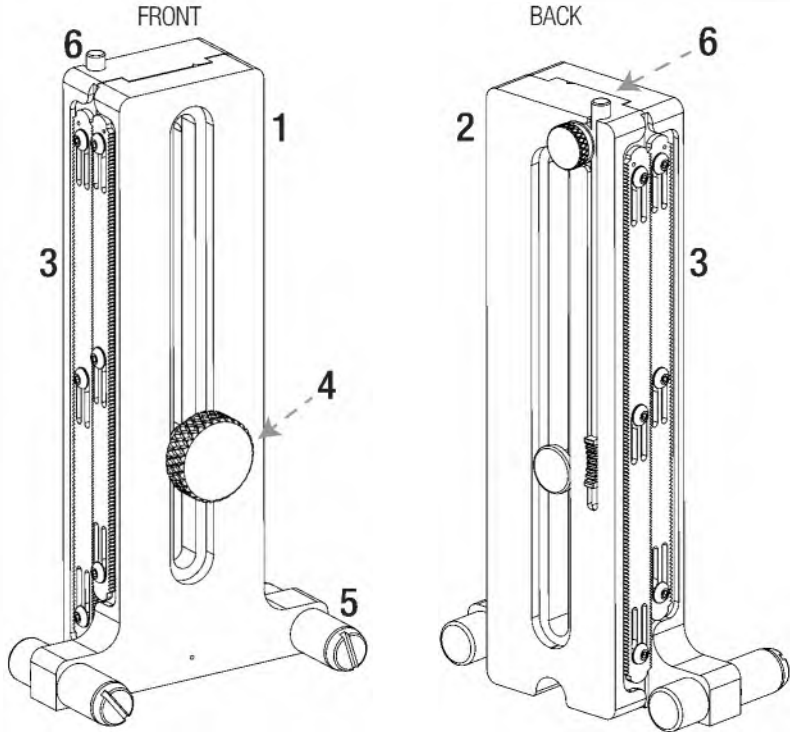

- | | |
|------------------------------|-------------------|
| 1. Base | 4. Locking Knob |
| 2. Slider | 5. Centering Foot |
| 3. Incremental Locking Racks | 6. Depth Rod |

Woodpeckers 6-IN-1 Pocket and Shop Gauges provide a convenient way to accomplish multiple tasks in your shop. The incremental racks lock measurements in precisely, making machine set-ups and work gauging simple and accurate. The 6-IN-1 features a height gauge, depth gauge, restricted opening depth gauge, marking gauge, center finder and a vee-shaped drill bit depth setting gauge.



Scan the QR code above to watch the video or visit woodpeck.com under the video tab towards the bottom of the product page.

If you think you're missing anything, email us at mailroom@woodpeck.com. You can also call us at 800-752-0725 from 9:00 a.m. to 4:00 p.m. EST Monday - Friday.

• HEIGHT GAUGE

To use the 6-IN-1 Gauge to set your saw blade or router bit height, loosen the Locking Knob and adjust the Slider to the desired dimension using the scale titled "Height - Drill Bit Depth" (on the inside of the Base).

Tighten the Locking Knob.

Place the 6-IN-1 above the cutter and adjust the depth of cut until the cutter just kisses the bottom of the Slider. **FIGURE A**

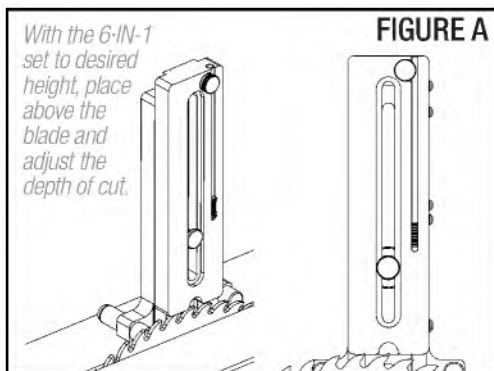

• DEPTH GAUGE

Set the desired depth using the "Marking Gauge Depth" scale (on the inside of the Slider).

Rest the Base on the upper surface and observe the fit of the Slider to the lower surface. A flush, "light drag" fit on both surfaces indicates proper depth of cut.

FIGURE B

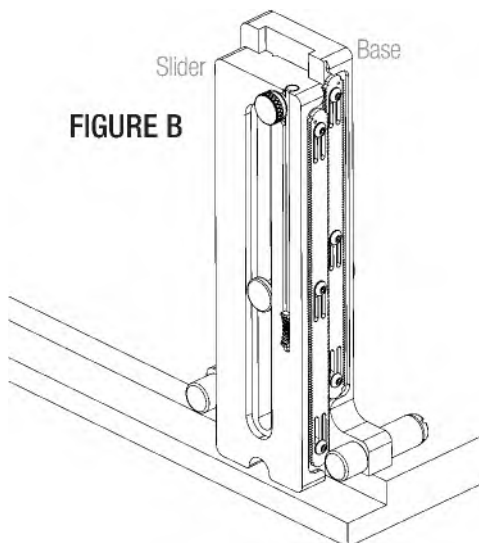

• MARKING GAUGE

Use the "Marking Gauge Depth" scale (on the inside of the Slider), to set the desired dimension.

Tighten the Locking Knob.

Position the 6-IN-1 with the bottom of the Base along the edge of the workpiece and the inside surface of the Slider on top of the workpiece.

Place a pencil tip in the small notch on the Slider.

Slide the 6-IN-1 and pencil along the workpiece. **FIGURE C**

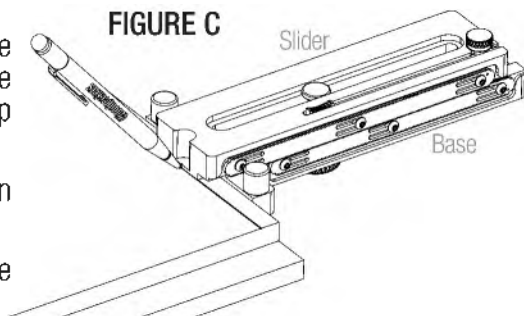

• HOLE DEPTH

Adjust the 6-IN-1 until the Base and Slider are even and lock the Locking Knob.

Place the top of the 6-IN-1 on the workpiece, loosen the Depth Rod Lock and lower the Depth Rod into the hole or groove to be measured until contact is made with the bottom of the material.

Tighten the Depth Rod Lock.

The flag on the Depth Rod will indicate the depth on the adjacent scale.

FIGURE D

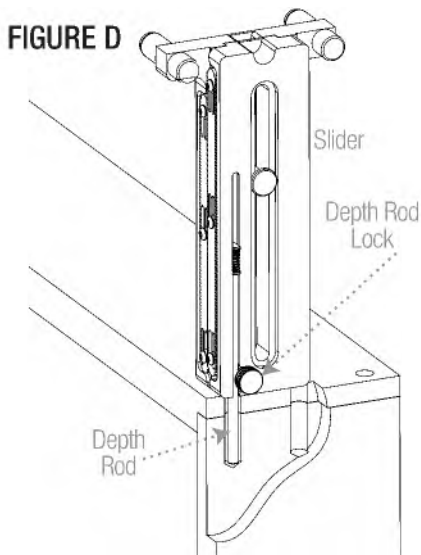

• DRILL STOP

Use the scale titled "Height - Drill Bit Depth" (on the inside of the Base), to set the desired drilling depth.

Tighten the Locking Knob.

Place the drill bit in the vee-groove on the inside of the Slider

Set the drill stop collar to the end of the Slider and secure. **FIGURE E**

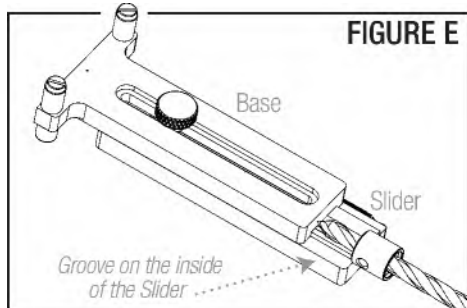

• CENTERLINE MARKING

Loosen the Locking Knob and move the Slider away from the bottom of the Base.

Place the "toe" side of the Centering Feet on the workpiece with one foot on each side of the stock. **FIGURE F**

Rotate the 6-IN-1 until both Centering Feet are in contact with the workpiece.

Place a pencil tip in the small hole in the Base.

Keep both Centering Feet firmly on the workpiece and slide the 6-IN-1 and pencil along, marking the centerline.

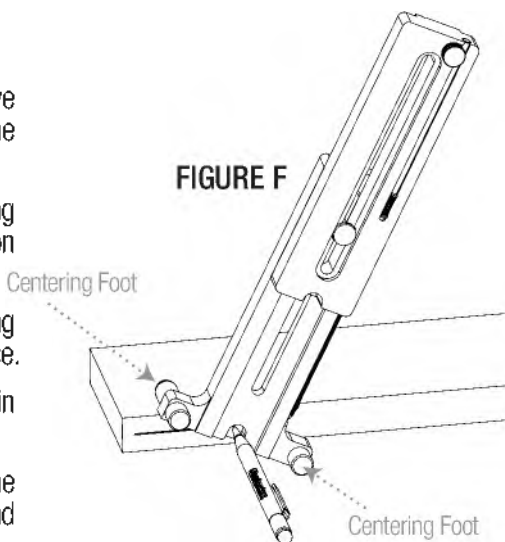

SWITCHING BETWEEN IMPERIAL & METRIC MEASUREMENT

NOTE: A small hole is located on the METRIC SIDE of each of the Incremental Locking Racks.

FIGURES G-1 & G-2

Loosen the Locking Knob slightly.

Use a 1/16" Allen wrench to loosen the (6) Button Head Screws that secure the Incremental Locking Racks to the 6-IN-1 and remove them. **FIGURE H**

Flip the Incremental Locking Racks over.

NOTE: The small holes on the Incremental Locking Racks must be on the same end of the 6-IN-1. With both holes out, the teeth engage at 1/32nd of an inch intervals. With both holes in, the teeth engage at 1mm intervals.

Install the (6) Button Head Screws & Washers finger tight only.

Set the Base and the Slider upright and flush on a flat surface.

Tighten the Lock Knob.

Ensure the teeth of the Incremental Locking Racks are meshed and tighten the (6) Button Head Screws.

Incremental Locking Racks set to IMPERIAL.
Small holes on the outsides.

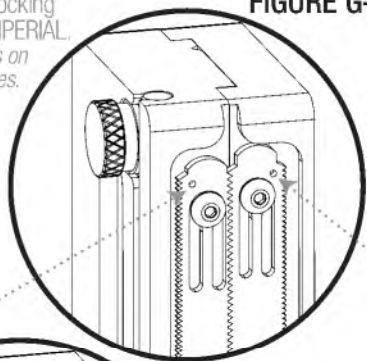

FIGURE G-1

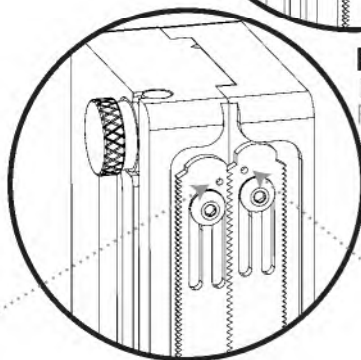

FIGURE G-2
Incremental Locking Racks set to METRIC.
Small holes on the insides.

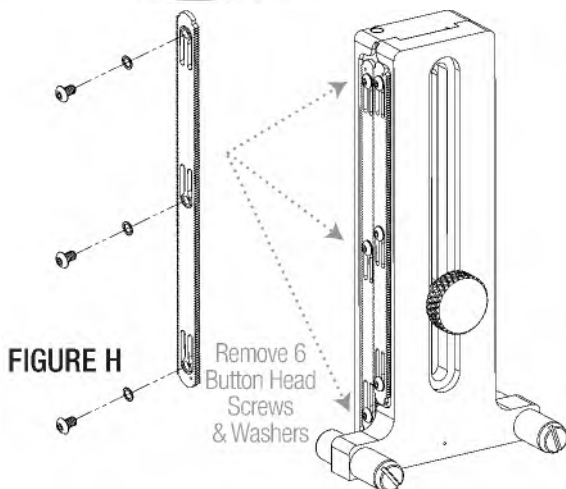

FIGURE H

Woodpeckers®

Woodpeckers, LLC Strongsville, Ohio

woodpeck.com

© 2024 Woodpeckers, LLC



woodpeck.com

At Woodpeckers we are constantly reviewing & improving our tools. The most current version of our instruction manuals are always available to download at woodpeck.com.

(Located in the bottom section of the tool's page under the "Additional Information" or "Instructions" tabs.)



WARNING! This product can expose you to chemicals, including chromium, which is known to the State of California to cause cancer and birth defects or other reproductive harm. For more information go to www.P65Warnings.ca.gov