

Woodpeckers®

MORTISING JIG

OWNER'S MANUAL

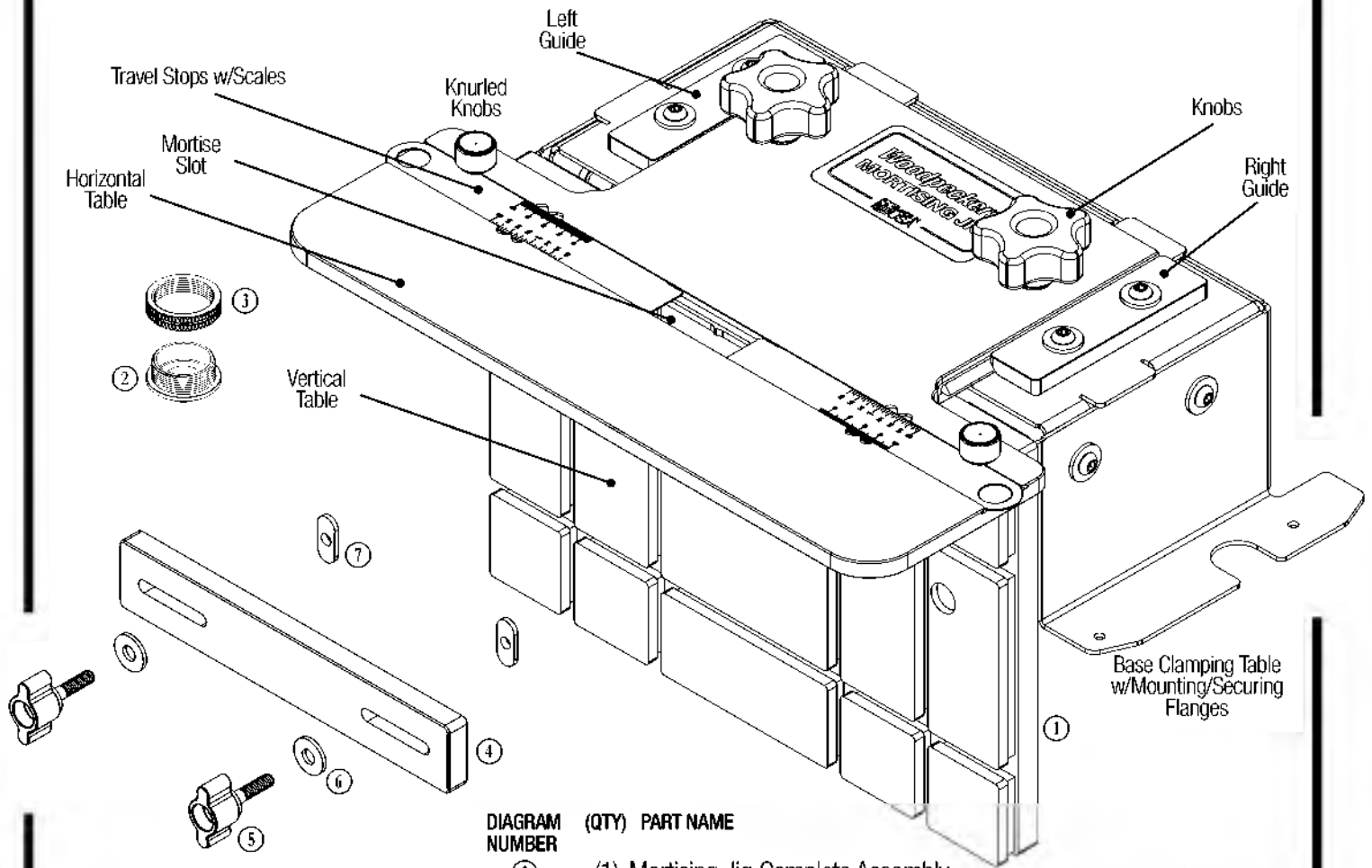

Clamps sold separately.



Scan the QR code above to watch the video or visit woodpeck.com under the video tab towards the bottom of the product page.

With the Mortising Jig, you can cut mortises for nearly any project:

- On the edge or end of your workpiece
- In square or round stock
- For workpieces mitered at any angle
- Placing the mortise centered or off-center of the board
- Cutting repeatable mortises for joining boards in a panel

If you think you're missing anything, email us at mailroom@woodpeck.com.
You can also call us at 800-752-0725 from 9:00 a.m. to 4:00 p.m. EST Monday - Friday.

I. ASSEMBLY

Your Mortising Jig comes pre-assembled. The Workpiece Stop is assembled by threading the (2) Knobs (5) and Washers (6) through the openings in the Workpiece Stop (4) and into the Oval Nuts (7). See the Parts Diagram on Page 1.

The included Guide Bushing (2) (3) is sized for the slot in the Mortising Jig and fits any Porter-Cable style router base attachment.

II. LAYING OUT YOUR MORTISE

With the Mortising Jig, you just need to lay out the vertical and horizontal centerlines (crosshairs) for your mortise. The length, width, and depth of the mortise are determined by the Travel Stops, router bit selection, and depth of cut, respectively.

III. SETUP & USE

- Securely clamp the Mortising Jig to your work surface. You can do this in several ways:
 - Use track clamps through an MFT-style table.** The notches in the Flanges are designed for tables with 20 mm holes on 96 mm centers.
 - Use F-style clamps on the flanges.** When placing clamps, you may need to angle the clamp so it does not impede the tracks in the vertical table or protrude past the face of the Vertical Table.
 - For a more permanent installation,** you can drive screws through the pre-drilled holes in the Flanges directly to the work surface.
- Open the Mortise Slot all the way by loosening the Knurled Knobs and sliding the Travel Stops w/ Scales outward. You should be able to see all four center indicator marks. *Figures A & A-1.*
- Align and clamp the workpiece:
 - With a clamp ready to secure the workpiece, align your workpiece flush with the underside of the Horizontal Table and clamp the workpiece with your crosshairs visible in the window. *Figures B & B-1.*
 - Clamp the workpiece in place while you adjust the Horizontal Table.
 - Be sure to always mark the show face of your board(s) to ensure correct reference and alignment of joining pieces.
- Adjust the Horizontal Table and workpiece to your mortise crosshairs.
 - Loosen both Knobs and adjust the Horizontal Table in or out to center the crosshair to the horizontal indicator marks in the slot. Re-tighten the Knobs. *Figure B-2.*
 - Loosen the clamp and adjust the workpiece to align the vertical crosshairs to the indicator marks in the slot. *Figure B-3.*
 - Clamp the workpiece firmly to the table and add additional clamps as necessary. Ensure that a clamp is located towards the top of the workpiece. *If all clamps are all located at the bottom, the router bit may grab and move the workpiece with tough grains.*
 - If you are making multiple, repeatable cuts, clamp the Workpiece Stop along an edge to index similar parts. *Figure C.*
- Choosing your router bit (mortise width):
 - You can rout mortises with any plunging router bit up to 1/2", or 12mm, in diameter. This will define your mortises width (thickness of the tenon).
 - Always use an upcut router bit.

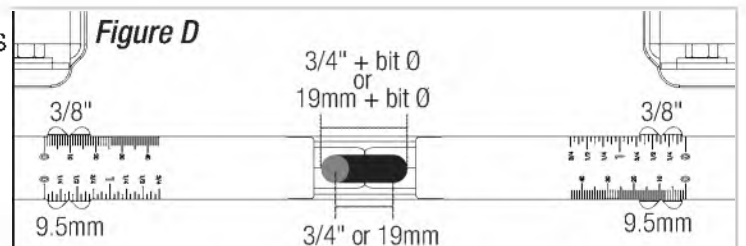
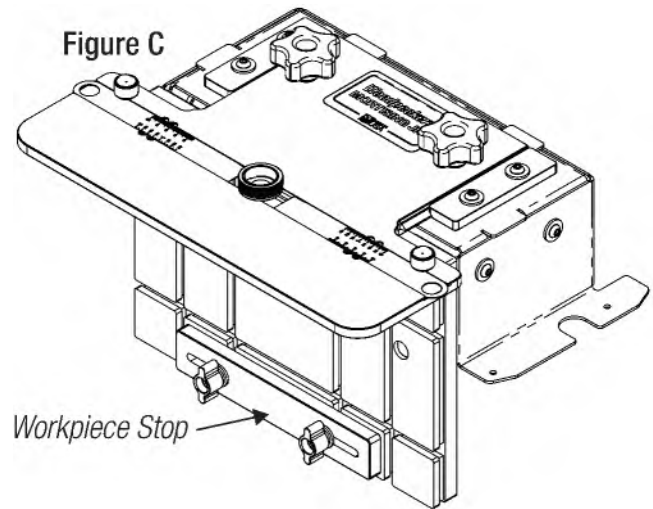
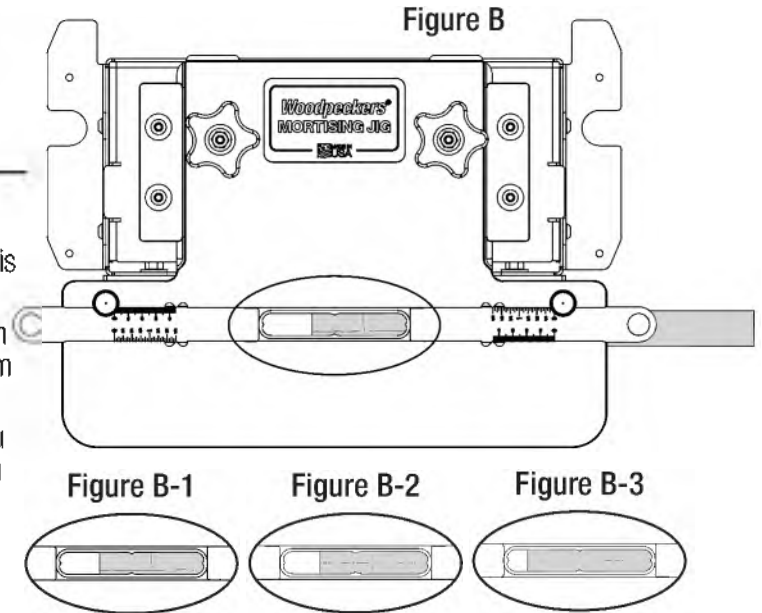
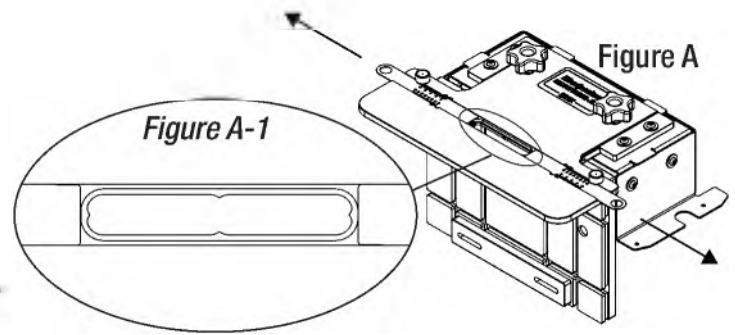

NOTE: Each side of the Scale indicates the length of travel from the center of the mortise, to the center of the router bit. When setting the total length of the mortise, you must include the cutting tool's radius on both scales. See Figure D.

6. Set the length of your mortise:
 - A. Loosen the Knurled Knobs and adjust the Scales to the desired inch or millimeter setting and re-tightening the Knurled Knobs.
7. Set the depth of your mortise
 - A. Install the desired router bit into your plunge router and the Guide Bushing on your router base. Ensure that your guide bushing is properly centered on your router for best results.
 - B. Place your router on the Mortising Jig.
 - C. Zero the depth stop by plunging until the bit hits the workpiece and locking the stop in place.
 - D. Adjust the depth of cut by adding your mortise depth to the zero position on the depth stop.
8. Rout your mortise:
 - A. Safely rout your mortise by removing small amounts of material at a time. You can either rout side-to-side in multiple shallow passes, or bore straight down along the length of your mortise with shallow cleaning passes.
 - B. Periodically clear any dust that may hinder the Guide Bushing's travel. Some recommend plunging both ends then making shallow, side-to-side passes. Try out which methods work best for you.

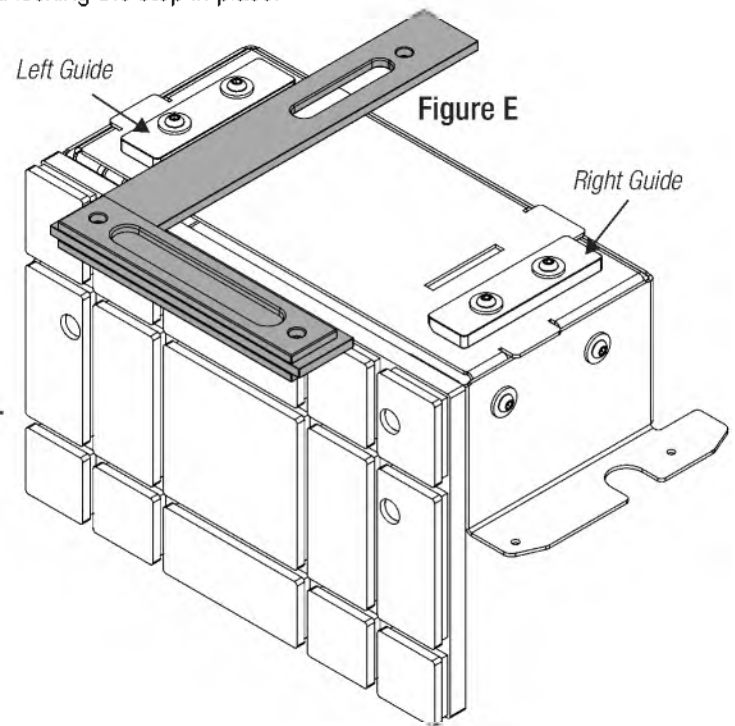

IV. CALIBRATING THE MORTISING JIG

Each Mortising Jig is assembled and squared at the factory. If your Mortising Jig needs to be re-squared due to movement in shipping, follow the steps below.

1. Calibrating the mortise parallel to the Clamping Table:
 - A. Remove the Horizontal Table by removing the two Knobs and sliding the table out, free of the Guides.
 - B. Loosen both side Guides screws using a 5/32" hex key. **Figure E.**
 - C. Using a reliable square (*not included*) registered on the Vertical Table, hold the Left Guide against the square while tightening the screws.
 - D. Re-install the Horizontal Table and Knobs, leaving the Knobs loose.
 - E. Tighten the screws on the Right Guide while applying light pressure to hold the Guide in place.
 - F. Move the Horizontal Table in and out to ensure it will slide without any side-to-side play. Fine adjust the Right Guide if necessary by loosening the screws, adjusting the Guide with light pressure, and re-tightening.
2. Calibrating the Vertical Table perpendicular to the Horizontal Table.
 - A. Loosen the (4) screws in the sides of the Base using a 5/32" hex key. **Figure F**
 - B. Using a reliable square (*not included*), adjust the Horizontal Table so that it is square to the Vertical Table. Clamp the square to the table if necessary. **Figure G.**
 - C. Re-tighten the (4) screws in the sides of the Base to lock the Vertical Table in place.
3. If the Horizontal Table is difficult to move or doesn't slide straight.
 - A. Remove the Horizontal Table by removing the (2) Knobs and sliding the Table out, free of the Guides.
 - B. Wax the underside of the Horizontal Table and the top of the Base, wiping away any excess.
 - C. Rub a small amount of wax on the wedge shape on the side of the Horizontal Table.
 - D. Re-install the Horizontal Table and slide back and forth. Re-apply wax if necessary.
 - E. Once complete, re-install the Horizontal Table and the Knobs.

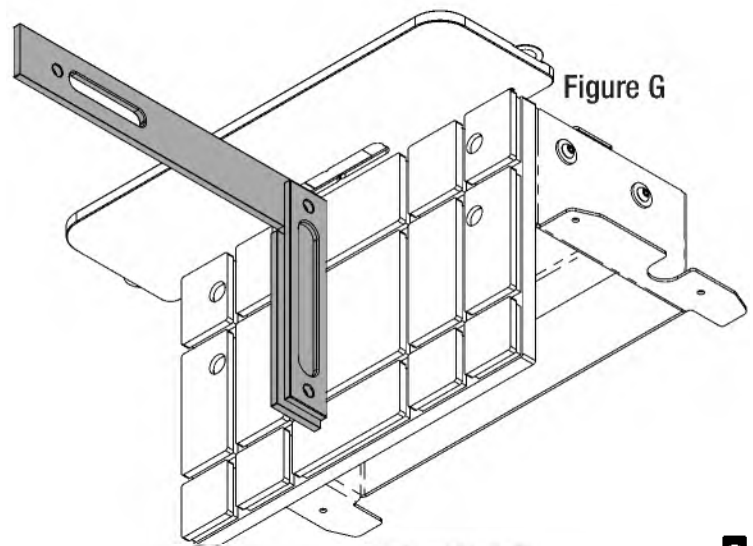
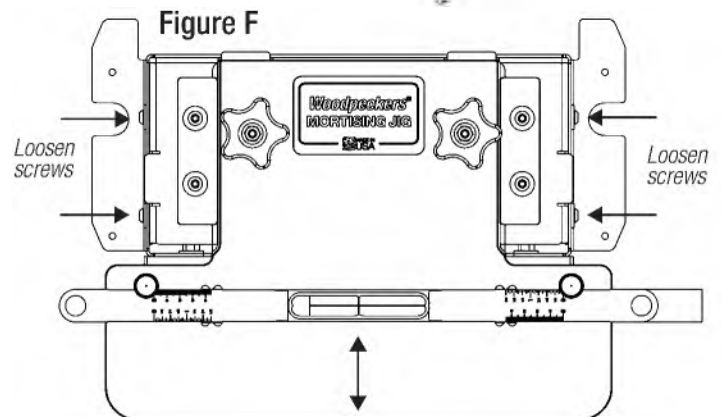

V. GETTING TO KNOW YOUR MORTISING JIG

This short (~30 min.) three-way miter project is designed to allow you to test the functionality of your new Mortising Jig.

What You'll Need:

- Mortising Jig
- Plunge Router
- Plunging Router Bit
- (3) Pieces of 6" length Square Stock
- (3) Loose Tenons - *of the same thickness as your router bit.*

1. Getting started:

- Mill your square stock to the desired thickness.
- Cut 45° miters on two adjacent ends on each piece, ensuring the two miters align at the sharp corner.
- Select your loose tenon size (*we used stock milled to 6mm thick and rounded over with an Ultra-Shear Metric Half-Round bit*) and install the corresponding router bit in your router.
- Lay out your mortise centerline crosshairs on both miters of one workpiece. Place them where you like. We used a metric bit, so we thought it would be simpler to dimension everything in millimeters. **Figure 1**
- With your Mortising Jig clamped to a table, align the first mortise crosshairs to the horizontal table. (*See Part III, 3-4, page 2*). Clamp the Workpiece Stop against the edge of the workpiece to use as a template for the two similar cuts.
- Set your mortise length and depth. We used 6mm travel on either stop and 6mm depth. (*See Part III, 6-7, page 3*).

2. Rout your mortises:

- Rout the first mortise (*See Part III, 8, page 3*). Test the fit with your loose tenon and adjust your settings as necessary. The length should be close, but can be slightly larger than the loose tenon.
- Rout the other two workpieces on the same side of the double-miter.
- Following the same steps, align the complementary mortise crosshairs to your Mortising Jig and clamp the workpiece and the Workpiece Stop in place.
- Rout the other three mortises.

3. Putting it all together:

- Install the two tenons in one workpiece and one in another.
- Align the three-way miter joint, and squeeze the joints together. Add some glue if you wish.

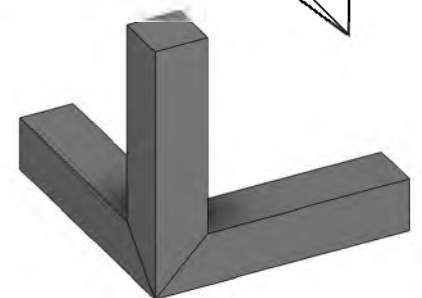
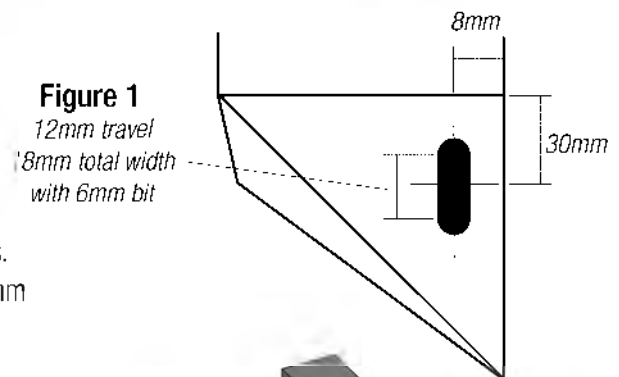
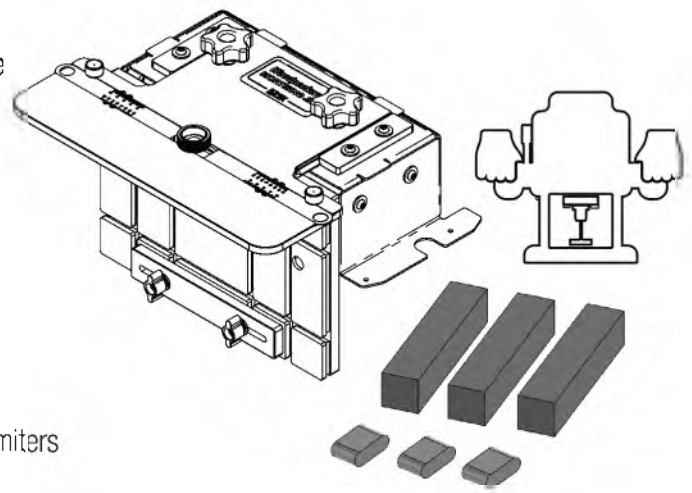

WARNING! To reduce the risk of injury keep hands away from moving parts. Refer to your power tool manual for proper setup and use.



WARNING! To reduce the risk of injury, wear safety goggles or glasses with side shields, ear protection & a dust mask.

Woodpeckers®

Woodpeckers, LLC Strongsville, Ohio

woodpeck.com

© 2024 Woodpeckers, LLC



woodpeck.com

At Woodpeckers we are constantly reviewing & improving our tools. The most current version of our instruction manuals are always available to download at woodpeck.com.

(Located in the bottom section of the tool's page under the "Additional Information" or "Instructions" tabs.)



Be the first to know all the new products, **OneTIME Tools & sales** by subscribing to our eClub. (Located at the top center of our webpage woodpeck.com.)



Subscribe to our YouTube channel to stay up-to-date on all the latest tool tips & tricks.



INTERACT WITH US! Follow us on Facebook, Instagram & TikTok!



Enjoy shop tips, project ideas, tool techniques & more in our Woodworking Resource Center/Blog. (Located at the bottom center of our webpage woodpeck.com.)



WARNING!

This product can expose you to chemicals, including chromium, which is known to the State of California to cause cancer and birth defects or other reproductive harm.

For more information go to www.P65Warnings.ca.gov