

# **Woodpeckers<sup>®</sup>**

## **OFFSET BASE SYSTEM**

### FOR FESTOOL DOMINO

#### OWNER'S MANUAL

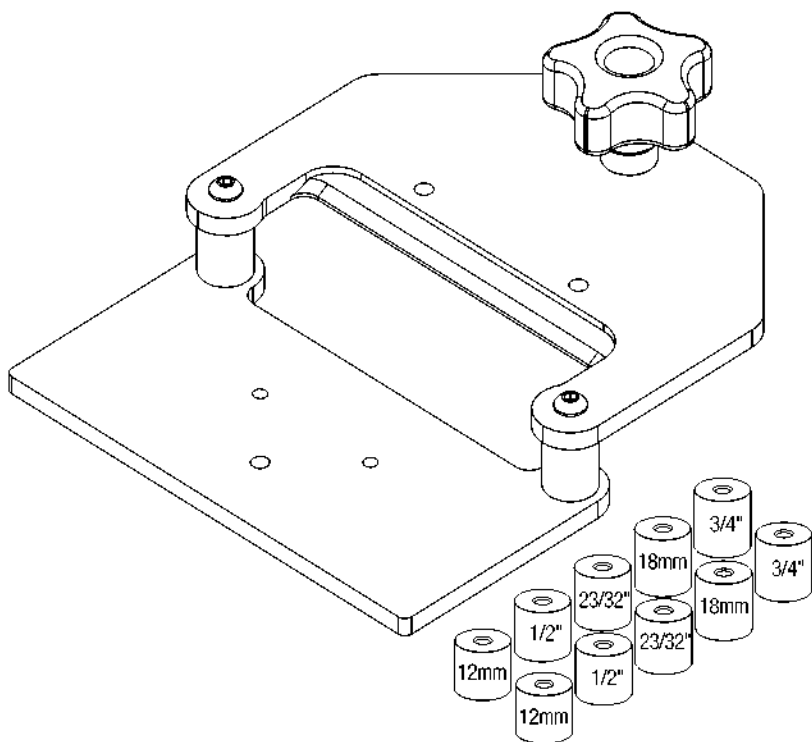

**Woodpeckers Offset Base System** makes the revolutionary Festool Domino perform better than ever. Our base provides an amazingly rigid platform that insures proper mortise geometry even when making large runs of cabinets and furniture parts.

The **Offset Base** comes with five pairs of spacers; 12mm, 1/2", 23/32", 18mm and 3/4" and (8) .005" Shims.

The **Offset Base System** comes with all above **PLUS** (4) Outrigger Tracks with Connectors and (4) Flip Stops.

If you think you're missing anything, email us at [mailroom@woodpeck.com](mailto:mailroom@woodpeck.com). You can also call us at 800-752-0725 from 9:00 a.m. to 5:00 a.m. EST Monday - Friday.

## INSTALLING SPACERS

The spacers are designed for use with either the Festool Domino DF500 or the XL DF700. Each spacer is marked with the thickness of material it's designed to match up with. For instance, the 3/4" spacers will position a mortise in the approximate center of a 3/4" board's edge. The board's actual thickness as well as slight variations in the joiners cutting action will influence the mortises true position. A set of (8), .005" shims are provided to fine tune the mortise's actual position.

Always make sure both spacers match. For the DF500, install spacers using 1/4-20 x 1/2" socket button head screws on top and 1/4-20 x 1/2" flat head screws on the bottom. *Figure 1*

For the XL DF700, add the 5mm Adapters and use the longer 1/4-20 X 3/4" flat head screws on the bottom. *Figure 2*

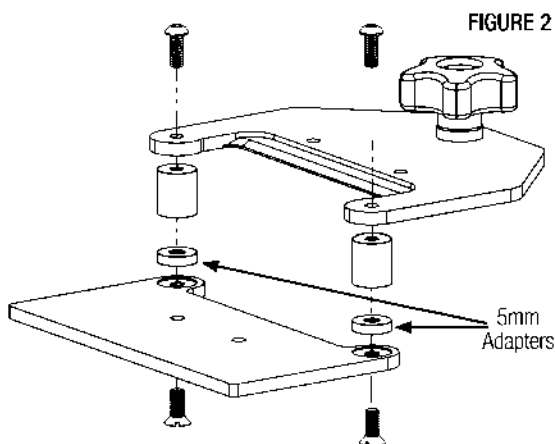
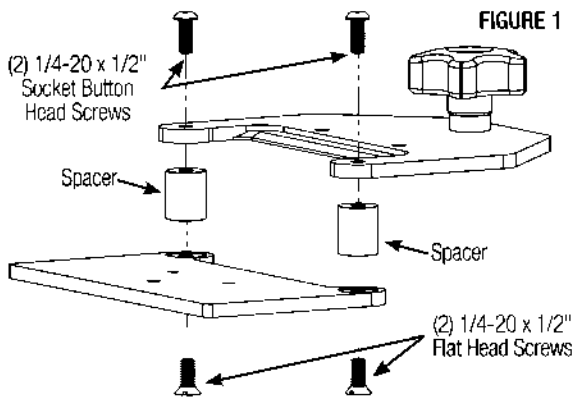

## OPTIONAL ACCESSORY

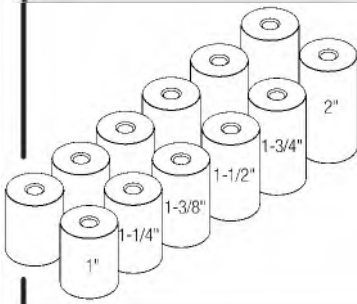

### EXPANDED SPACER SET

The optional Expanded Spacer Set includes spacers to match up with thicker material. They're installed and used the same way as standard spacers. If using with the XL DF700, remember to add the 5mm Adapters and use the longer flat head screws.

### SHIMS

A set of (8) .005" shims are included to fine tune the mortise position for a better match with the varying thicknesses of common sheet goods, solid lumber. *Figure 3*

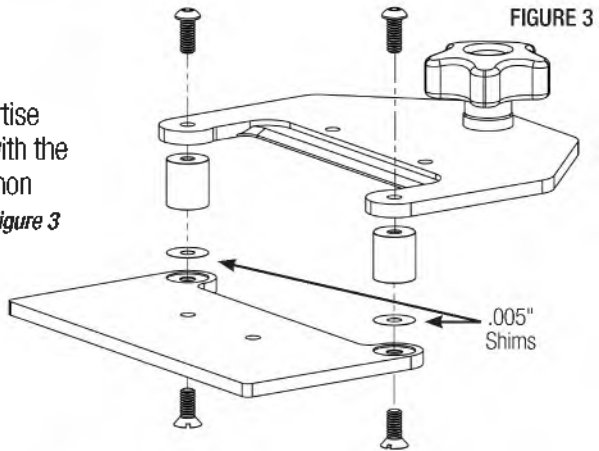

## OPTIONAL ACCESSORY

### TABLE APRON SPACERS

The optional Table Apron Spacers make it easy to set back table aprons from the outside leg face. Choose the appropriate spacers for the set back you desire, 1/8", 3/16" or 1/4" (Figure 6).

Apron mortises should be centered using the spacers that match up with their thickness without the additional Table Apron Spacers. Make sure to use

the longer, 1/4-20 X 3/4" flat head screws up through the bottom plate. *Figure 4*

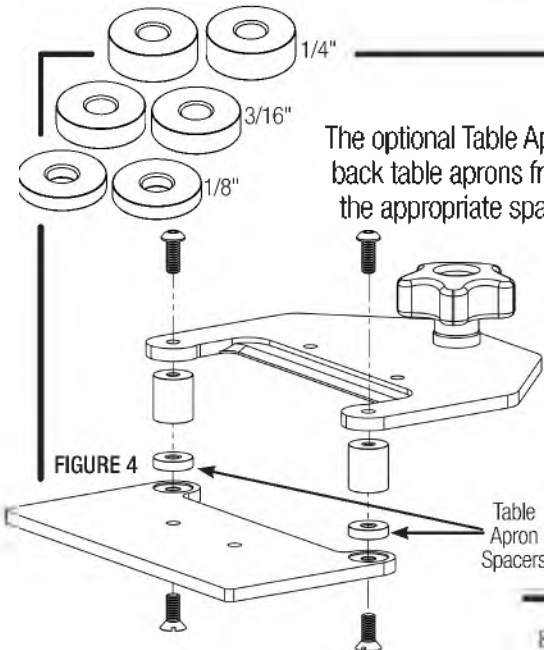

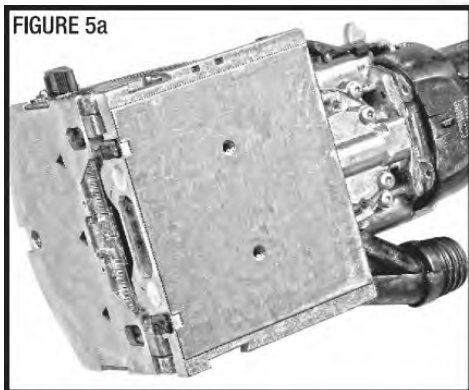

FIGURE 5a

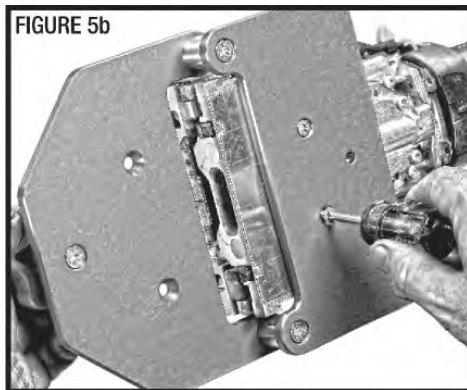

FIGURE 5b

## ATTACHING TO YOUR JOINER

Use the 5mm flat head screws to attach the offset base to either the DF500 or XL DF700. *Figures 5a & 5b*



FIGURE 6

Align your pencil line with the center "0" mark on the scale.



## USING THE OFFSET BASE

Begin by marking a line on your board where you want to make a mortise. Position the Offset Base so that the mark you made is aligned with the engraved white mark at the center of the Offset Base scale. Hold down firmly on the red knob and operate your joiner normally. *Figure 6*

## OPTIONAL ACCESSORY

### INSTALLING THE OUTRIGGER TRACK

Insert two 1/4-20 x 1/2" flat head screws up through the bottom of the top plate and loosely start the two oval nuts. With the scale facing up, slide the track onto the plate while engaging both oval nuts. *Figure 7*

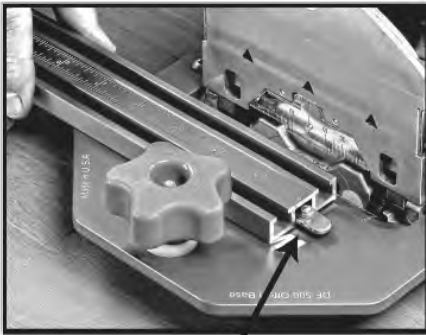

FIGURE 7

Carefully align the mark on the side of the track with the center mark on the top of the base plate and tighten the two screws. *Figure 8*

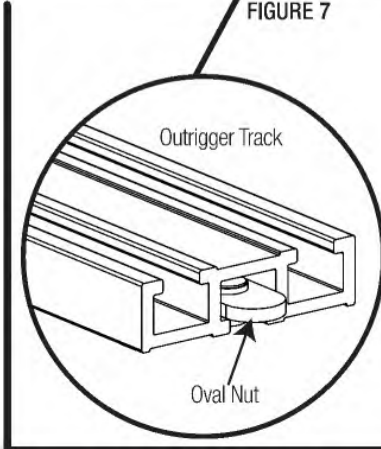
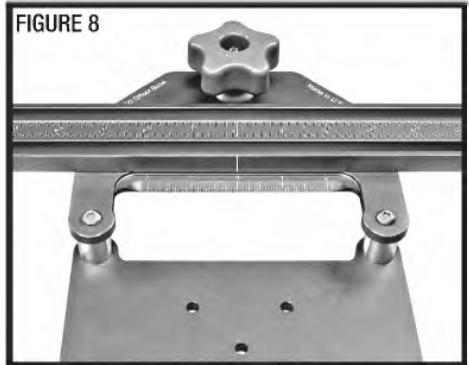

FIGURE 8



## OPTIONAL ACCESSORY

### ATTACHING ADDITIONAL OUTRIGGER TRACKS

Multiple segments of track can be joined to form a longer track by using the Track Connectors. Insert a connector half way into the center slot of the first piece of track and tighten the screw using the supplied hex key. Attach the next piece of track the same way and tighten the other screw. *Figure 8*

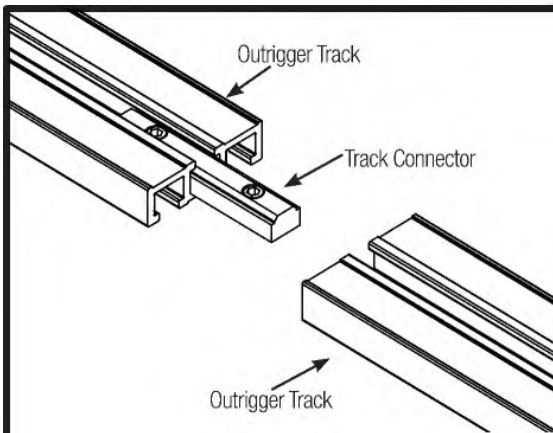

FIGURE 8

## OPTIONAL ACCESSORY

### USING FLIP STOPS WITH THE OUTRIGGER TRACK

Repeating mortise patterns along the edge of multiple boards is easiest by using the flip stops. Simply arrange the stops along the tracks scale at the locations you wish to cut a mortise. With all the stops flipped down, begin at the stop closest to the joiner, make your mortise, raise the stop and advance to the next one. Repeat for each board. *Figure 9*

FIGURE 9



### MATCHING MORTISE LOCATIONS ON MATING PIECES

To make matching mortises on mating pieces of wood, disconnect the second outtrigger track from the first one, spin it around to the other side and re-attach. Now you will have perfectly aligned mortises without the need to adjust or reposition the flip stops. *Figure 10*



FIGURE 10

## OUTRIGGER FOOT

The Outrigger Track comes with a foot that keeps the Domino from tilting when being used.

To install, insert the flat head screw through the bottom of the foot and screw on the oval nut just enough to hold it in place. *Figure 11*

Next, insert the oval nut into the bottom slot of the outrigger and position it on the track and tighten the screw. *Figure 12*

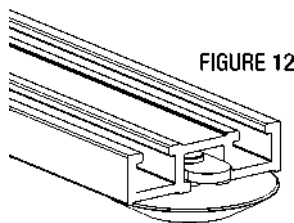
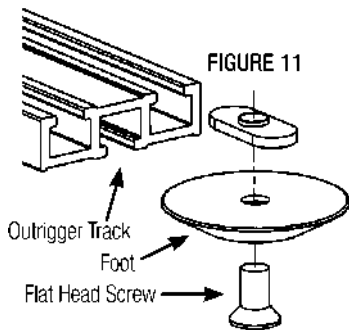

## HELPFUL HINTS

To get the most out of the Offset Base System, it's recommended that you practice on scrap material first. Just a few joints will help you become familiar with the feel of the tool.

If your system came with the outrigger and flip stops, it's especially beneficial to practice mating two pieces of material together. Because the layout of mortises isn't likely to be perfectly symmetrical along the boards length, it's necessary to work from opposite ends of the two boards.



Rather than moving the flip stops, it's much faster to just loosen the first Track Connector and flip the outrigger to the other side as is shown. *Figure 13*

Going through this process even once will help to clarify how this method works.

NOTE: The Festool brand name is the registered trademark of the respective companies and are not associated with Woodpeckers, LLC.

**Woodpeckers®**

PRECISION WOODWORKING TOOLS

Woodpeckers, LLC Strongsville, Ohio · ***woodpeck.com***

© 2020 Woodpeckers, LLC

REV021320



**WARNING!** This product can expose you to chemicals, including chromium, which is known to the State of California to cause cancer and birth defects or other reproductive harm. For more information go to [www.P65Warnings.ca.gov](http://www.P65Warnings.ca.gov)