



www.kregtool.com
800.447.8638

Jig & Fixture Bar KMS7303

About the Jig & Fixture Bar

This 30" aluminum bar is perfect for use in a variety of woodshop jigs and fixtures. The bar is 3/4" wide by 3/8" thick and will fit into the miter slot of most standard table saws, router tables, and band saws. The bar contains eight plugs that adjust with the turn of a screwdriver to take up any excess room in the miter slot for a perfect fit

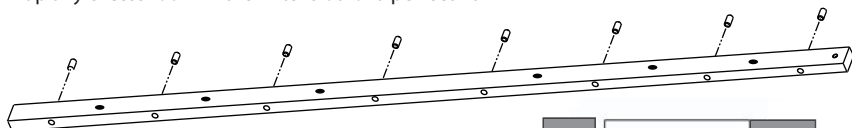

Cutting to Length

Table Slot

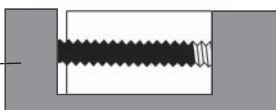

This 30" jig and fixture bar is the ideal length for use in a standard table saw slot as it will remain fully engaged in the slot when pushed entirely past the blade. With that being said, the bar can be cut in half if needed to produce two identical Jig and Fixture Bars. To cut, simply mark the bar with a pencil, secure into a vise, and cut with a hacksaw. You may want to deburr the edge of the bar to remove any sharp edges.

Mounting the Jig & Fixture Bar

The Jig and Fixture Bar contains countersunk holes that will accept #8 x 3/4" screws. In most applications, you will want to surface mount the bar to the bottom of a 3/4" piece of plywood to create a runner system that will slide in the bottom of a miter slot. It is not recommended to use a runner in both slots of the tablesaw as a binding action could occur when material swelling and contraction take place.

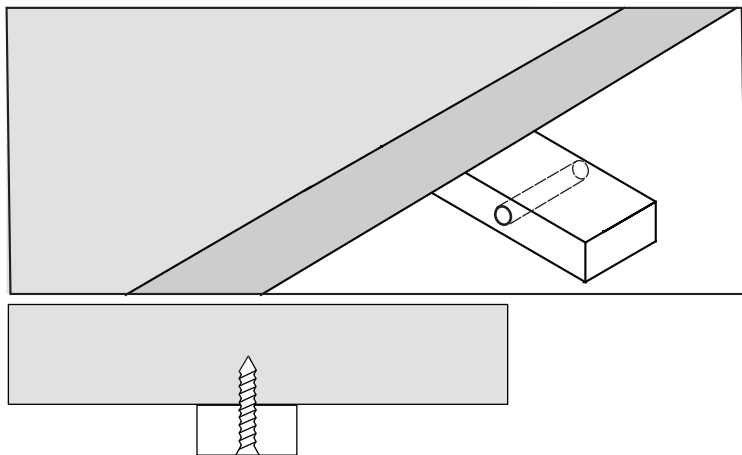

Adjusting the bar to the Miter Slot

The bar contains eight plugs that adjust to fill the miter slot. You will need a small, slotted screwdriver to turn the plugs. Start all six plugs so that they all travel in the same direction. Install fully so that each plug reaches the opposite edge of the bar. Place the bar into the miter slot and pull the first plug to the edge of the miter slot and pull the first plug to the edge of the miter slot. Test for play by wiggling back and forth. If there is play, pull the plug out of the edge of the miter slot and adjust to expose the plug from the edge of the bar. Slide the bar back into the slot and retest for play. Continue this process for the remaining plugs.

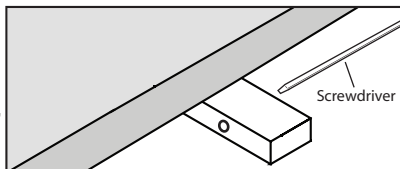

Jig & Fixture Bar Applications

The Jig and Fixture bar can be used in a variety of applications. Most revolve around a runner system for a table saw slot or band saw slot.

