

# The Woodpecker PlungeLift™ Installation Instructions

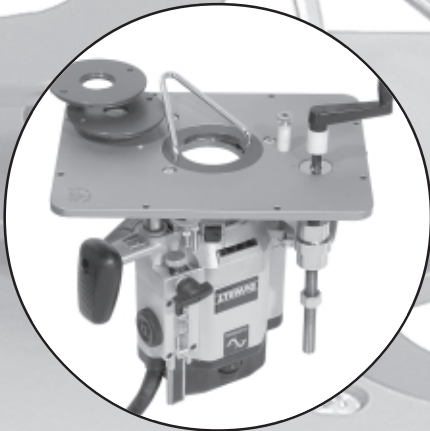

*Note: Installation requires removal of some router components. This may effect the manufacturers original warranty. Check with the manufacturer for details.*

## Step 1

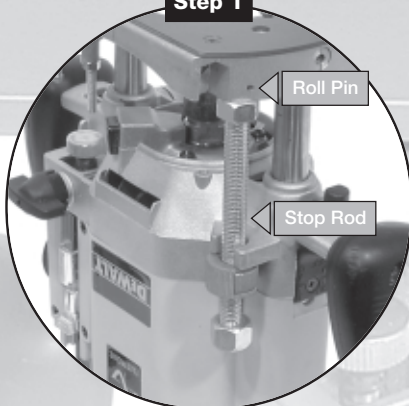

**Step 1** Using a small pin punch, drive pin in, through the threaded stop rod. Once the roll pin has been removed from the base, unscrew the threaded stop rod. Save stop rod and pin for future use.

## Step 2

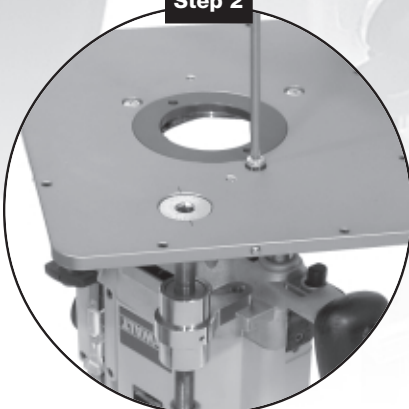

**Step 2** Position PlungeLift as shown over router base. (Do not remove brown sub-base.) Install and tighten (3) screws (supplied).

## Step 3



**Step 3** Orient support arm so that it is above attachment point on router. With support arm barely brushing against attachment point, install bolt, lock washer and both flat washers as shown. Tighten with 1/2" wrench.

# The Woodpecker PlungeLift™ Installation Instructions *cont.*

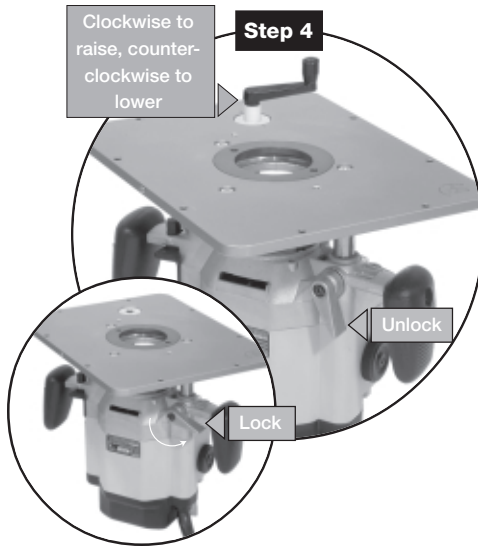

**Step 4** With the plunge lock lever in the unlocked position, rotate the crank handle clockwise to test for free motion. More resistance in the clockwise direction is normal due to the plunge springs in your router (do not remove the springs). If too much resistance is experienced;

1. Re-engage the plunge lock lever.
2. Loosen the support arm attachment bolt.
3. Rotate crank lever counter-clockwise until support arm is just free of contact with lift point.
4. Re-tighten attachment bolt.
5. Release the plunge lock lever (down).
6. Repeat rotation of crank handle to see if ease of height adjustment has improved.
7. Repeat procedure as necessary.

Always make sure plunge lever is locked and remove crank handle before attempting any routing operations.

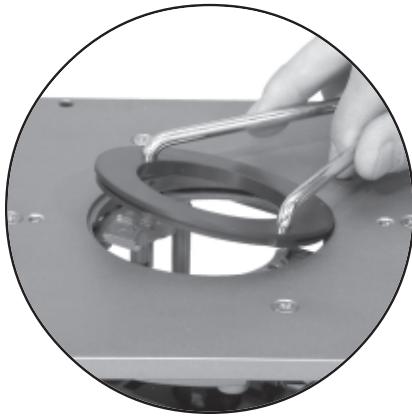

**Changing Rings.** Three different rings are included with your PlungeLift. A 1" I.D., 1 3/16" I.D. and a 2 1/2" I.D., (shown). These rings can be removed or installed with the spanner wrench. Engage two short legs of wrench into two small holes in ring. Rotate ring **CLOCKWISE** and lift to remove. To install ring, set ring into recess until it is flush with top of plate and rotate **COUNTER-CLOCKWISE** to lock into position.

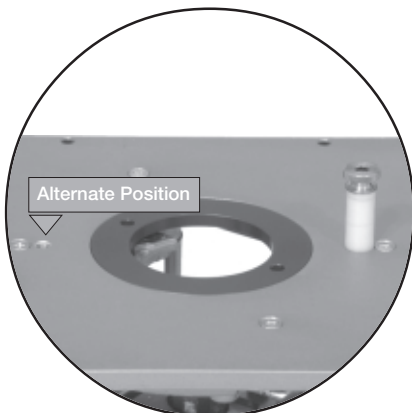

**Starting Pin.** Your PlungeLift also comes with one starting pin. This pin is used when performing edge-forming operations. It is designed to add an element of control when starting cuts. The starting pin can be used in two different positions. Make sure starting pin is firmly tightened before using.

